



Service Parts & Dimensions

6000-1.05

Effective : April, 2009 (Replaces September, 2002)

20 SCFM Bronze Marine Filters USN-Rated per MIL-S-901C

Models:

- 2063S-6 Filter grade "A" shock
- 2063-6 Filter grade "C" shock (non-shock)

Capacity:

- 20 SCFM @ 100 psig
- 566 L/min @ 7 Kg/cm²
- 34 m³/hr @ 7 bar

Dimensions:

Overall - 12-1/8" (H), 5-1/4" (W), 5" (D)

Connections:

9/16-18 UNF-2B Straight Thread

Cartridges:

- Two (2) Element Design -
- 1st Stage Scrubber (coalescing)
- 2nd Stage Polisher (adsorptive)

Material:

Filter Body & Sump - Bronze

Shock Rating:

Grade A - Grade A conforms to MIL-S-901C for high-impact shock applications. Non-shock model conforms to Grade C designations.

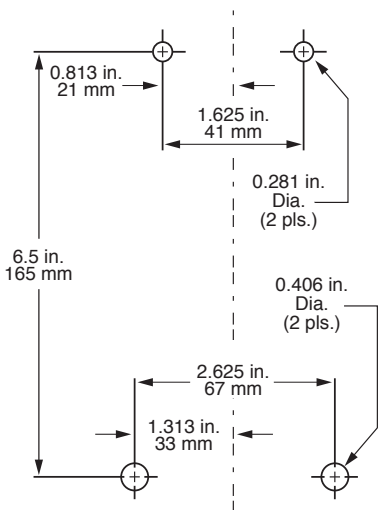
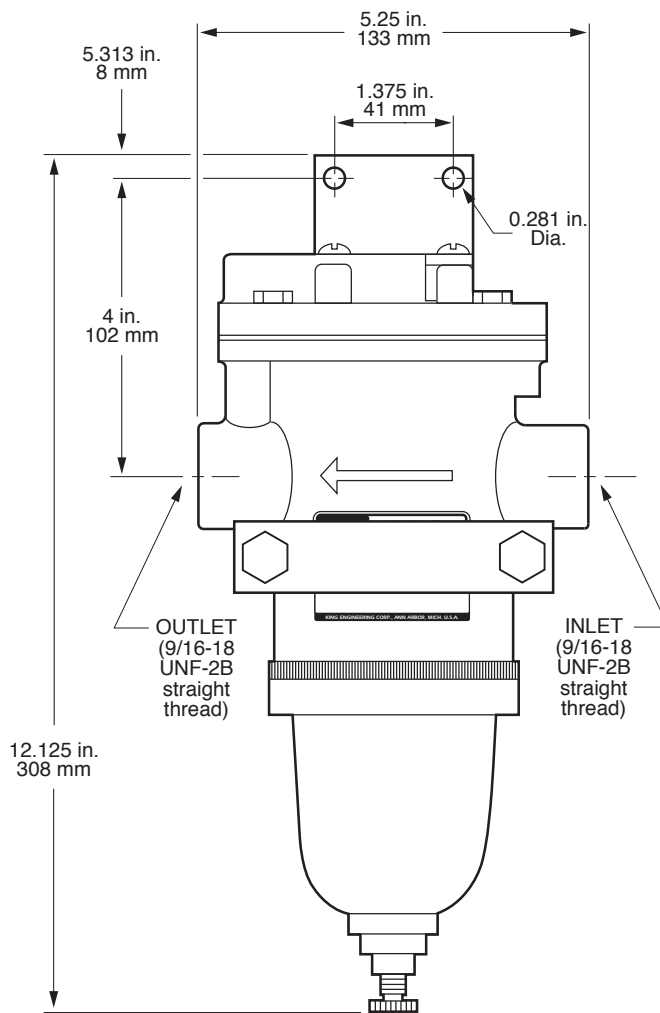

Mounting Dimensions

Inside:

- Installation Instructions.....page 2
- Service Partspage 3
- Cartridge Replacement.....page 4

End-Use Filters

Filtering the entire compressed air system at one central location does not generally provide sufficient cleaning for all end-use applications. Moreover, most compressed air piping contains some amount of rust, scale and condensed liquids. Water vapor that may be present in warm air will tend to condense into liquid when the air cools.

A compressed air filter installed just upstream of the end-use is generally the most efficient means of ensuring clean, dry air. These end-use filters can provide clean air to meet individual process requirements. A coalescing filter should be specified due to its long service life where liquid contaminants may be encountered.

Do not undersize a compressed air filter. Exceeding the listed flow rate of the filter will have a proportionate

decrease in the service life of the cartridge elements. Frequent cartridge replacement necessitated by undersizing an application significantly increases maintenance costs. Maximum efficiency is generally obtained between 15%-100% of the maximum rating.

Vapor and Condensation

Many types of pneumatic equipment and processes use compressed air that must be clean, dry and oil-free. This requires the removal of liquids, aerosols, dust and solid particulates from the airstream. Generally, only condensed liquids need to be removed. Visible fog or mist is actually composed of condensed liquid droplets. These are easily removed by using a coalescing compressed air filter at the end-use point.

Vapor is liquid in evaporated form. In this gaseous state, the liquid vapor will be invisible. Oil and water vapor are commonly present in compressed air systems. If either type of vapor must be removed, a compressed air dryer must be used. Desiccant dryers, for instance, use media that attracts the vapor molecules through a process called "adsorption".

Application Note

Manufacturer's warranties are void in the event of misapplication or negligence and manufacturer assumes no responsibility for loss under such circumstances.

Installation Instructions

1. Locate filter in coolest location in air system.
2. Install drip leg upstream of filter.
3. Locate filter as near end use as possible.
4. Always make inlet connection to port marked "Inlet" on the filter.
5. Auto Drain requires minimum 20 psi (1.4 kg/cm²) inlet pressure for proper operation.
6. Pressure gauges installed on both sides of the filter are useful to indicate when filter is being used in its proper flow range and also indicate when cartridges need replacing.
7. Pressure rating 150 psig. Maximum temperature is 200° F./93° C.
8. It is important to the proper operation of the filter that the sump be drained daily (or be equipped with auto-drain). Failure to do this may cause permanent damage to equipment down-stream of the filter.

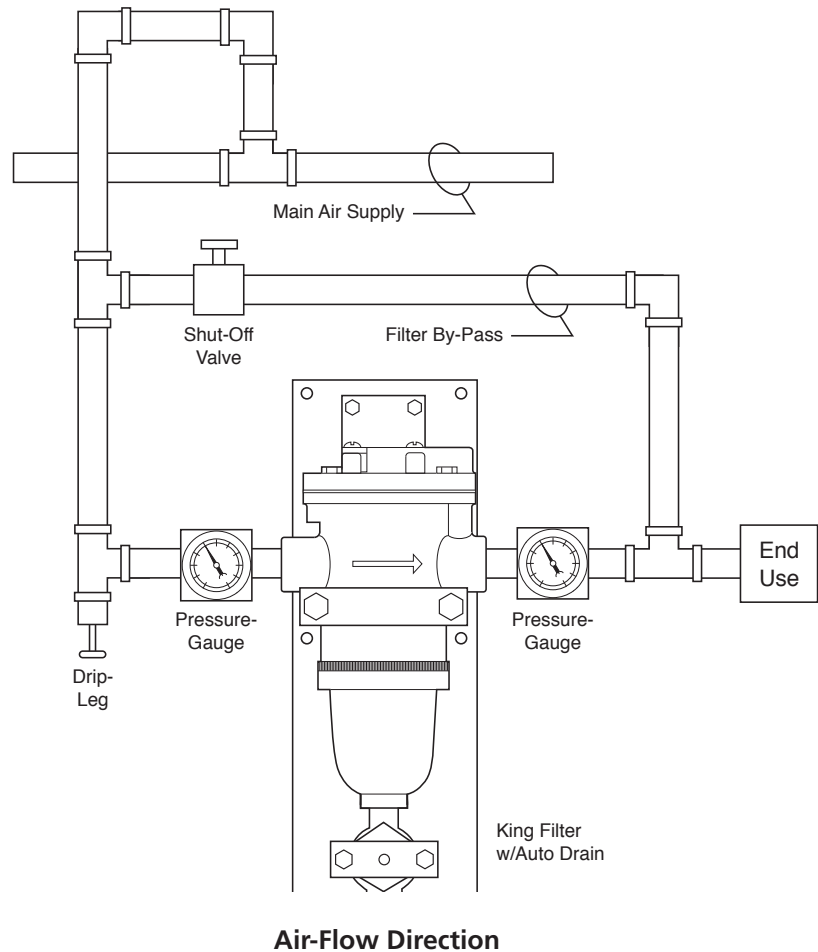

Replacement Filter Cartridges:

(Standard)

0.1 Micron Replacement Set A22-11-6-5
Type 750 Scrubber/Type 800 Polisher

Type 750 Scrubber only - Order no. 9318-80
Type 800 Polisher only - Order no. A31-1-5

(Optional)

2.0 Micron Replacement Set A22-11-1-1
Type 300 Scrubber/Type 300 Polisher

Type 300 Scrubber only - Order no. 9318
Type 300 Polisher only - Order no. A31-1-1

Note: Other cartridge grades are available.
Details upon request.

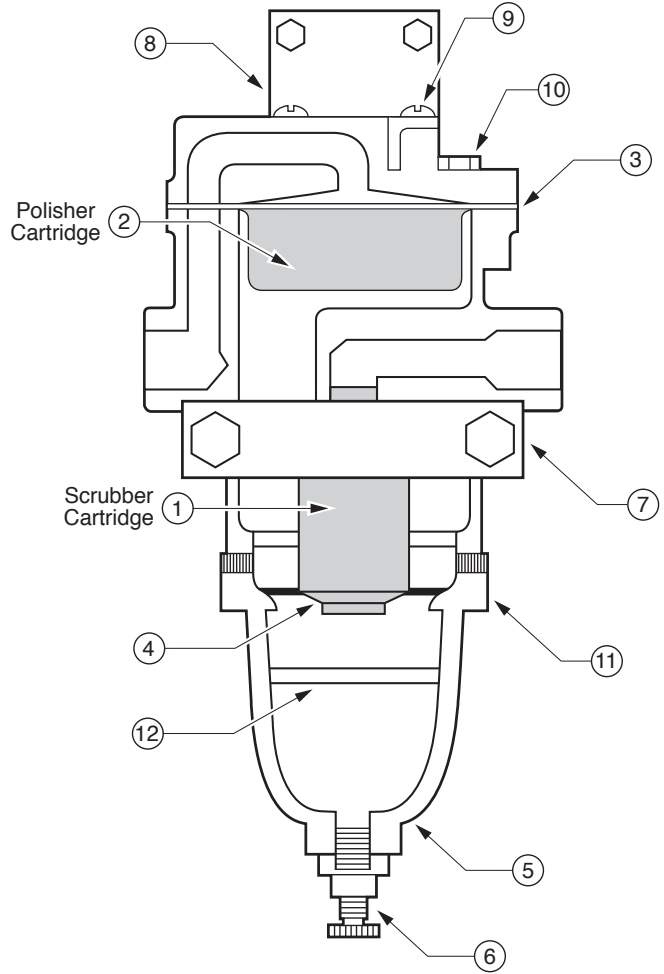

Item	Description	Part No.	Qty.
1	Scrubber Cartridge (1st Stage)	Above	1
2	Polisher Cartridge (2nd Stage)	Above	1
3	Gasket	9329	1
4	O-Ring	2200-109	1
5	Filter Sump, (bronze)	9315B-82	1
6	Manual Drain Petcock	6120-21	1
7	Shock Mount Bracket Assy.	6941-41NP	1
8	Mounting Bracket	7624-3NP	1
9	Bracket Screw	1544S-3	2
10	Housing Bolt	8279-19	4
11	Retaining Ring	9317-11NP	1
12	Baffle	5919-1	1
	Baffle Channel	8801-4	1

Notes:

1. Item 3 is included with Filter Cartridge Replacement Sets.
2. Item 1 includes o-ring, p/n 6495-10.
3. Item 5 includes o-ring, p/n 2200-109.

Application Note

Under normal operating conditions, the only servicing which need be done to a King filter is to change the cartridges. The number of times that this must be done will vary with each installation. Generally, the cartridges are changed when the pressure drop across the filter becomes objectionable.

To change the cartridges the following procedure should be followed:

1. Turn off the air supply and drain the filter. This will vent the filter of all compressed air.
2. Remove the sump.
3. By using a King Filter utility wrench (p/n 2585) or inserting the points of long nose pliers into the two slots in the bottom of the scrubber cartridge it can be unscrewed. Install a new scrubber cartridge and replace the sump.
4. Remove the four housing bolts from the top of the filter and lift off the cover plate. Remove the gasket and lift out the old polisher cartridge.
5. Drop in a new polisher cartridge followed by a new gasket and the cover plate. Tighten the four screws alternating from one to another until all are tightened.
6. Turn on the air supply and the filter will start functioning immediately.

Caution! it is important to the proper operation of the filter that the sump be drained daily (or be equipped with auto-drain). Failure to do this may cause permanent damage to equipment downstream of the filter.

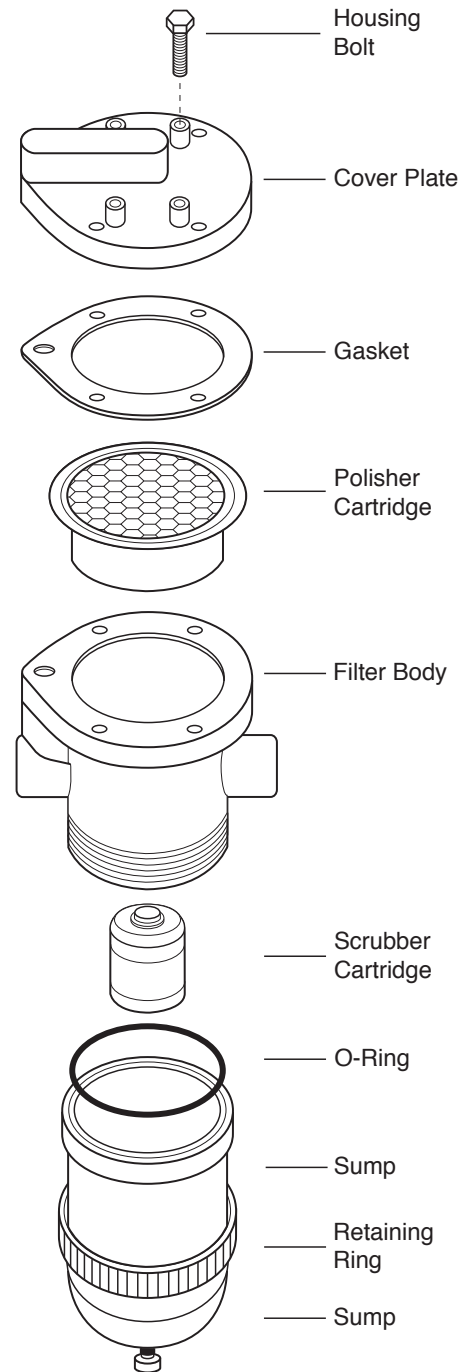

3201 South State, Ann Arbor, Michigan 48108 U.S.A.
PO Box 1228, Ann Arbor, Michigan 48106-1228
Phone: 734-662-5691 • FAX: 734-662-6652
www.king-gage.com

© King-Gage and the KE emblem are registered trademarks of King Engineering Corporation, Ann Arbor, Michigan, U.S.A.

All specifications are subject to change without notice

© 2002 King Engineering Corporation. All rights reserved