



INSTRUMENT GRADE Compressed Air Filters

Ultra Clean Air for Instrumentation, Fluidics, Packaging, and Laboratory

9460 Air-Guard Filter

60 scfm

- Provides Clean, Dry, Oil-Free Compressed Air
- Dual Stage Scrubber and Polisher Elements
- Energy Conserving Automatic Drain

KING Air-Guard Model 9460 compressed air filter with its 60 scfm flow rating is intended for main supply line applications where pipe scale, residual oil aerosols, and condensation can degrade air quality. The long service life afforded by the dual cartridge design ensures high performance filtration. Air-Guard Model 9460 is supplied with KING Type 750/800 element set that includes coalescing scrubber and adsorptive polisher cartridges. (Type 300/300 element set is an optional selection.)

The high efficiency coalescing first stage cartridges remove more than 99% of the dirt, oil and water aerosols from the air. The flow of air through these cartridges continuously sweep out the liquid contaminants into the sump (where they are discharged by the automatic drain). Under normal operating conditions, these cartridges retain their filtering efficiency throughout their service life.

The second stage polisher cartridge encompasses media that remove the last remaining harmful traces of oil, water and dirt to deliver exceptionally clean air at the outlet of the filter.



**Model 9460
Air-Guard
Compressed Air Filter**

Model No.	9460-3T (w/ auto drain), 9460-3 (w/ manual drain)
Rated Flow	60 scfm @ 100 psig; 1699 l/min @ 7 Kg/cm ² ; 102 m ³ /hr @ 7 bar
Connections	1" NPT
Max. Pressure	150 psi
Filter Type	dual cartridge coalescing elements
Efficiency	99.998% @ 0.1 micron



9460 Air-Guard Filter

60 SCFM TWO STAGE COALESCING FILTER

APPLICATIONS

Point of Use: Air operated packaging equipment, air preparation for painting/coating systems, improved machinery performance, and reduced maintenance.

Pneumatic Instruments: Installed upstream of the main take off to individual components, the filter provides clean, regulated compressed air. When used with KING-GAGE tank level systems, one (1) filter can service dozens of individual pneumatic tank sensors.

SPECIFICATIONS

AIR-GUARD FILTER

MODEL 9460-3T with automatic sump drain

MODEL 9460-3 with manual sump drain

Maximum Inlet Pressure: 150 psig (10.3 bar)

Capacity (Flow):

60 scfm @ 100 psig (102 m³/hr @ 7 bar)

Rated Efficiency: 99.998% @ 0.1 micron

Connections (Inlet/Outlet): 1" NPT, female

Temperature Limit: 200°F/93°C

Physical Data:

housing—cast aluminum

sump—cast aluminum

shipping weight—25 lb/11 kg

Sump Drain:

automatic, floated actuated (Model 9460-3T)

manual petcock (9460-3)

Cartridge Elements:

dual cartridge coalescing elements

22-31-6-5 set (type 750/800)

22-31-1-1 set (type 300/300)

All specifications are subject to change without notice.

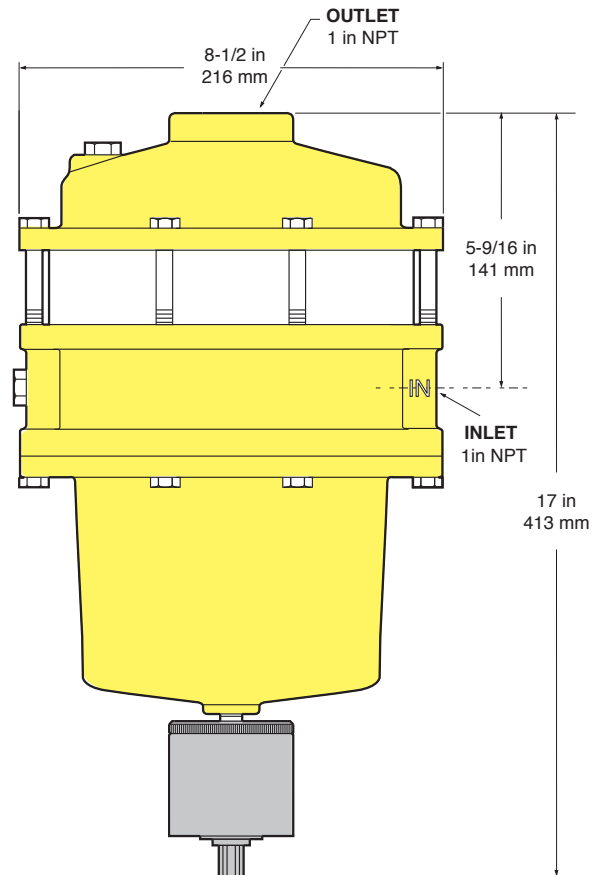

3201 South State Street, Ann Arbor, Michigan 48108-1625 U.S.A.

P: 734-662-5691 ■ F: 734-662-6652 ■ www.king-gage.com