



Service Parts & Dimensions

6000-1.20

Effective: April, 1993 (original release)

12 SCFM Metl-Guard Filter/Dryer

These units combine coalescing action filtration with a desiccant bed compressed air dryer. The double-action process removes solids, liquids and vapor.

Each Filter/Dryer includes a single high-efficiency type 750 scrubber cartridge. This primary stage utilizes a coalescing element to effectively remove liquid, aerosols and solid particulate from the airstream. The filter element is rated at better than 98% efficiency down to 0.1 micron. This prevents excessive saturation of the secondary stage desiccant bed, thereby ensuring longer service life.

Model Numbers:

- 1784-15 (w/ Manual drain)
- 1784-15T (w/ Auto-Drain)

Rated Flow:

- 12 SCFM @ 100 psig
- 340 L/min @ 7 Kg/cm²
- 20 m³/hr @ 7 bar

Connections:

- 1/2" NPT

Cartridges:

- Two (2) Element Design -
- 1st Stage Scrubber (coalescing)
- 2nd Stage Desiccant (vapor removal)

Physical Data:

- Housing - Aluminum
- Weight - 15 lbs./6.81 kg.

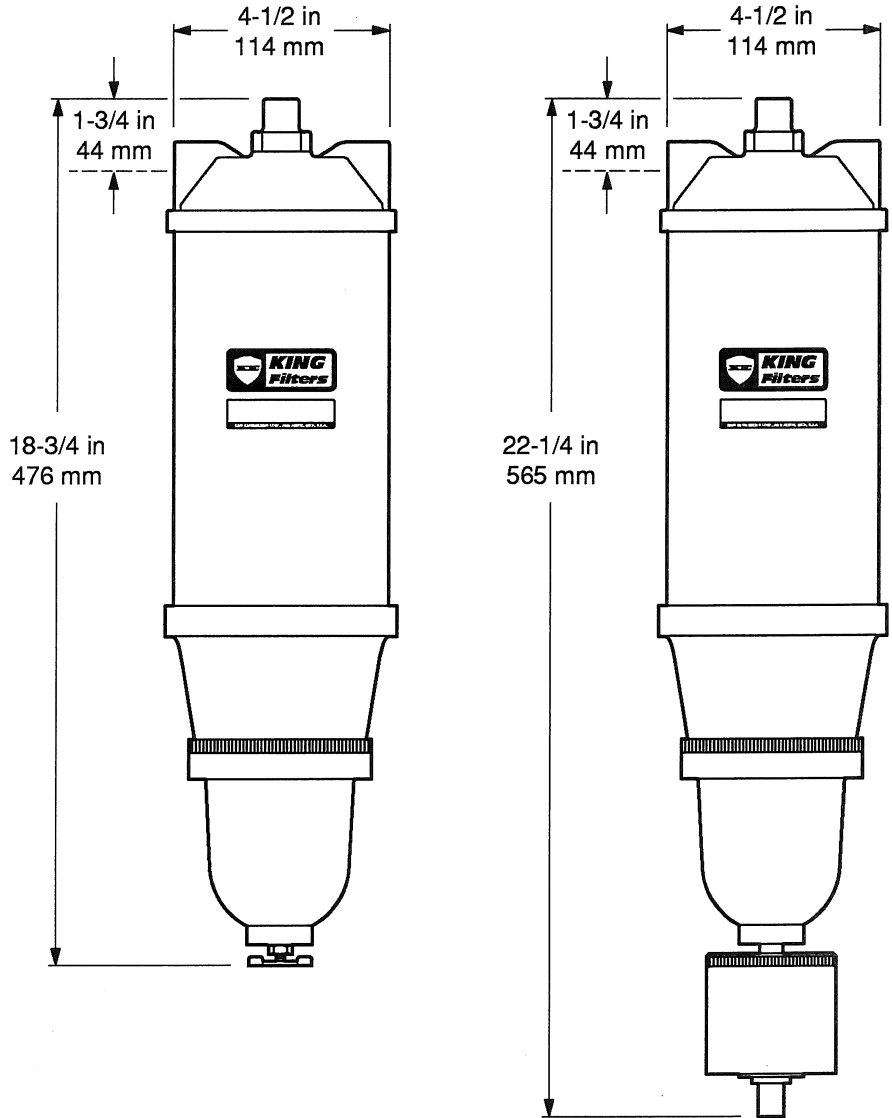

Inside:

Installation Instructionspage 2
 Service Partspage 3
 Cartridge Replacementpage 4

Installation Instructions

End-Use Filters

Filtering the entire compressed air system at one central location does not generally provide sufficient cleaning for all end-use applications. Moreover, most compressed air piping contains some amount of rust, scale and condensed liquids. Water vapor that may be present in warm air will tend to condense into liquid when the air cools.

A compressed air filter installed just upstream of the end-use is generally the most efficient means of ensuring clean, dry air. These end-use filters can provide clean air to meet individual process requirements. A coalescing filter should be specified due to its long service life where liquid contaminants may be encountered.

Do not undersize a compressed air filter. Exceeding the listed flow rate of the filter will have a proportionate decrease in the service life of the cartridge elements. Frequent cartridge replacement necessitated by undersizing an application significantly increases maintenance

Installation Instructions

1. Locate filter in coolest location in air system.
2. Install drip leg upstream of filter.
3. Locate filter as near end use as possible.
4. Always make inlet connection to port marked "Inlet" on the filter.
5. Auto Drain requires minimum 20 psi (1.4 kg/cm²) inlet pressure for proper operation.
6. Pressure gauges installed on both sides of the filter are useful to indicate when filter is being used in its proper flow range and also indicate when cartridges need replacing.
7. It is important to the proper operation of the filter that the sump be drained daily. Failure to do this may cause permanent damage to equipment downstream of the filter.

costs. Maximum efficiency is generally obtained between 15%-100% of the maximum rating.

Vapor and Condensation

Many types of pneumatic equipment and processes use compressed air that must be clean, dry and oil-free. This requires the removal of liquids, aerosols, dust and solid particulates from the airstream. Generally, only condensed liquids need to be removed. Visible fog or mist is actually composed of condensed liquid droplets. These are easily removed by using a coalescing compressed air filter at the end-use point.

Vapor is liquid in evaporated form. In this gaseous state, the liquid vapor will be invisible. Oil and water vapor are commonly present in compressed air systems. If either type of vapor must be removed, a compressed air dryer must be used.

Desiccant dryers, for instance, use media that attracts the vapor molecules through a process called "adsorption".

Application Note

Polycarbonate Sumps/Acrylic Cases

Polycarbonate sumps and/or acrylic plastic housings will be damaged if exposed to phosphate ester (synthetic) lubricants, chlorinated hydrocarbon solvents, methanol, acetone, ketones or lacquer solvents. Continued exposure to these compounds may result in premature failure of the pressure housing. Use only metal sumps/housings in environments where these materials and/or vapors are present.

Use of metal safety guards is generally recommended in certain instances, occupational safety regulations may require the use of metal guards or metal pressure housings.

Manufacturer's warranties are void in the event of misapplication or negligence and manufacturer assumes no responsibility for loss under such circumstances.

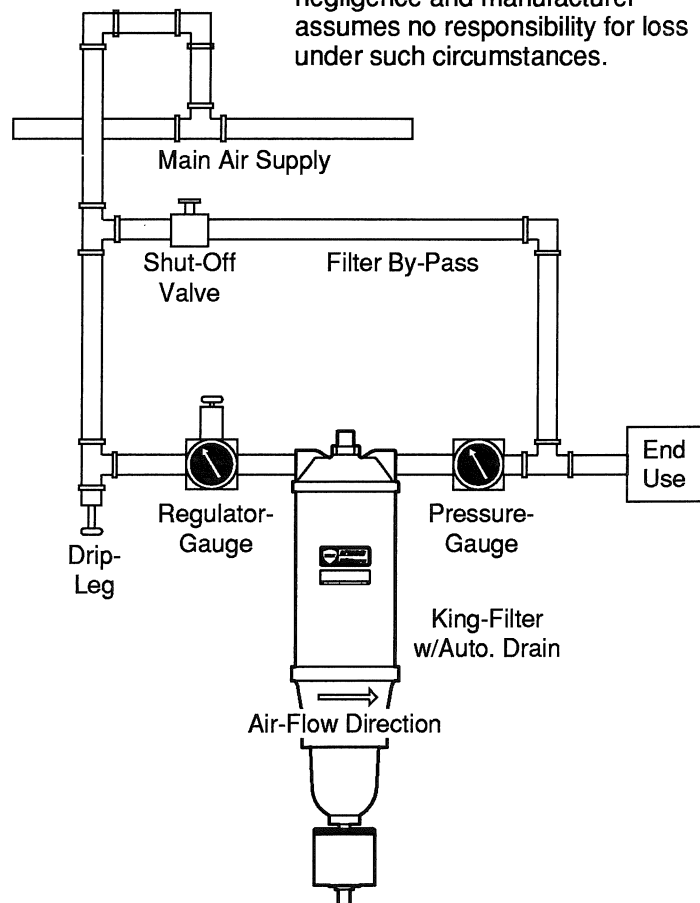

Replacement Filter Cartridges:

(Standard)

0.1 Micron Replacement
Type 750 Scrubber Only - 9318-80

(Optional)

2.0 Micron Replacement
Type 300 Scrubber Only - 9318

Desiccant Charge – Replacement Packs

Oil Vapor Removal	Temp. Limit
1730-4 AC-1 Activated Charcoal	120°F/49°C
1730-6 MS-2 Silicate	200°F/93°C

Water Vapor Removal	
1730 SG-1 Indicating Silica Gel	100°F/38°C
1730-5 MS-1 Silicate	200°F/93°C

Item	Description	Part No.	Qty.
1	Scrubber Cartridge	9318-80	1
2	Desiccant (note 1)	above	1
3	Dust Filter Pad (note 2)	1787	1
4	Screen Replacement Kit (note 3)	5910-1	1
5	Center Post Nut	1721-NP	1
6	O-Ring	6495-14	1
7	Metl-Bowl	6113-31	1
8	Filter Bowl Retainer Ring	9317-11	1
9	O-Ring	2200-109	1
10	O-Ring	6495-11	1
11	Manual Drain Petcock	6120-4	1
12	Auto-Drain	2465-36	1
13	Aluminum Sump	9315A-85	1
14	Gasket (note 4)	9329-21	2
15	Baffle	5919-1	1

Notes:

1. Includes item 3.
2. Included with item 2.
3. Includes upper and lower screens, (2) sealing gaskets.
4. Included with item 4.

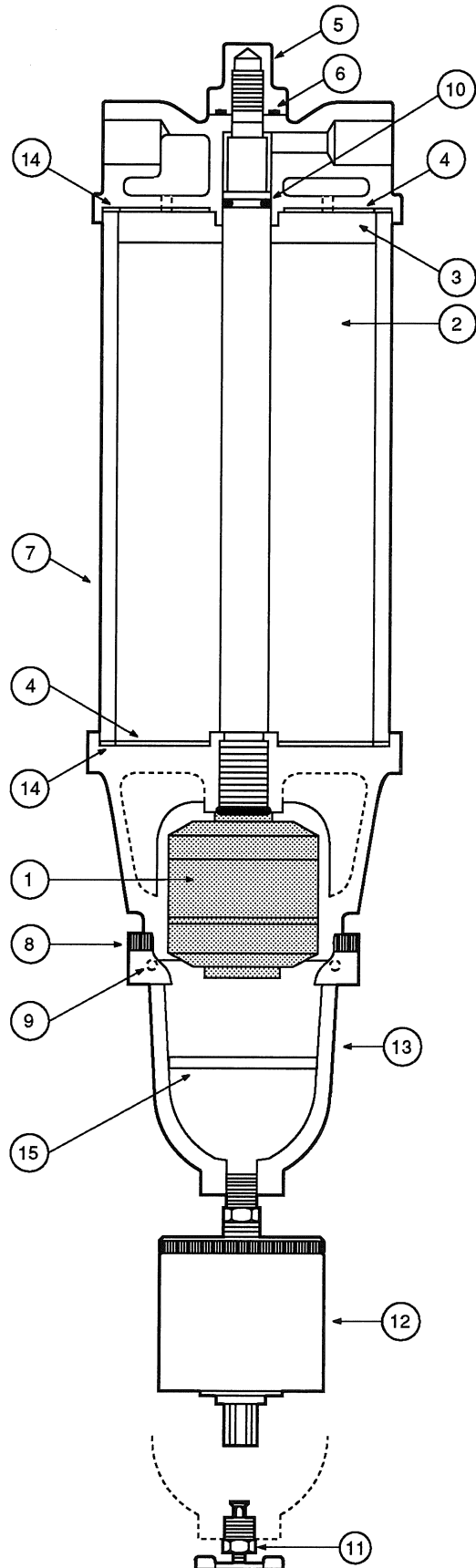

Cartridge Replacement

Under normal operating conditions, the only servicing which need be done to a King filter is to change the cartridge and desiccant. The number of times that this must be done will vary with each installation. Generally, the cartridges are changed when the pressure drop across the filter becomes objectionable.

To change the cartridge the following procedure should be followed:

1. Turn off the air supply and drain the filter. This will vent the filter of all compressed air.
2. Remove the sump.
3. By using a King Filter utility wrench (p/n 2585) or inserting the points of long nose pliers into the two slots in the bottom of the scrubber cartridge it can be unscrewed. Install a new scrubber cartridge and replace the sump.
4. Turn on the air supply and the filter will start functioning immediately.

Instructions for Installing Desiccant Charge:

1. Grasp base of dryer unit, unthread center post nut at top and remove lower assembly.
2. Empty the exhausted desiccant.
3. The seal between the bowl and lower assembly must be free of desiccant. When refilling, avoid pouring desiccant into center post.
4. Place dust filter pad over the bowl filled with desiccant. Reconnect bowl and lower assembly to the upper assembly, tightening center post nut securely to ensure proper seal.

Caution! it is important to the proper operation of the filter that the sump be drained daily. Failure to do this may cause permanent damage to equipment downstream of the filter.

