



Service Parts & Dimensions

6000-1.72

Effective : June, 2005 (replaces October, 2002)

KING Air Control Station Model 72 & Model 74

Model No.

7x- 024 - 6 - 25

Cartridge Code - Type
750 Scrubber/800 Polisher
standard

4 - with Auto Drain
2 - with Manual Drain
Petcock

Capacity: 20 SCFM @ 100 psig

Connections: 1/2 in. NPT (Inlet)
1/2 in. NPT (outlet)

Cartridges: 1st Stage Scrubber (coalescing)
2nd Stage Polisher (adsorptive)

Dimensions: Overall - 15" (H), 8-7/8" (W), &
5" (D). Detail below.

Material: Filter Body and Sump - Bronze
Regulator Body - Brass

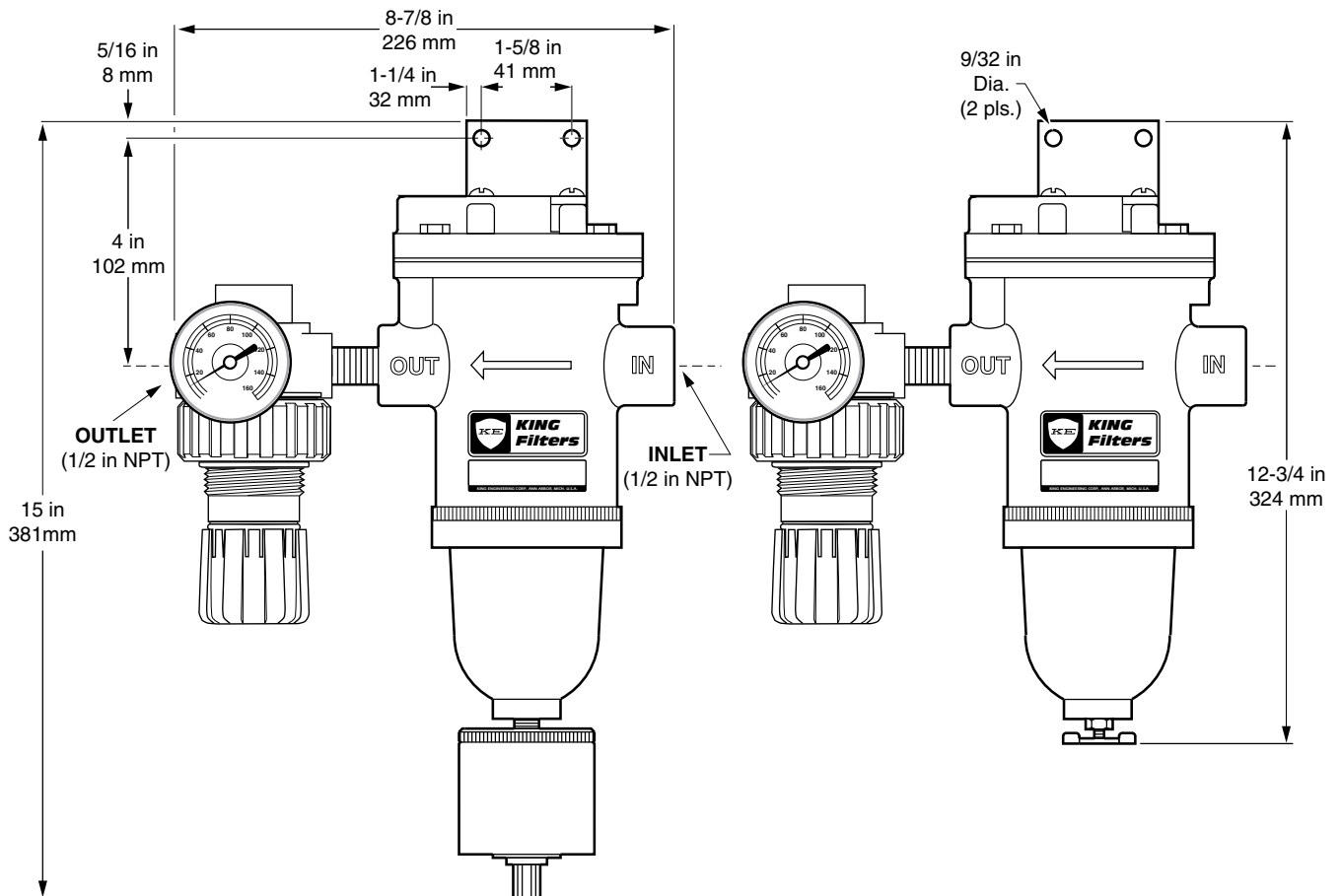

Replacement Filter Cartridges:

(Standard)

0.1 Micron Replacement Set A22-11-6-5
 Type 750 Scrubber/Type 800 Polisher

Type 750 Scrubber only - Order no. 9318-80
 Type 800 Polisher only - Order no. A31-1-5

(Optional)

2.0 Micron Replacement Set A22-11-1-1
 Type 300 Scrubber/Type 300 Polisher

Type 300 Scrubber only - Order no. 9318
 Type 300 Polisher only - Order no. A31-1-1

Note: Other cartridge grades are available.
 Details upon request.

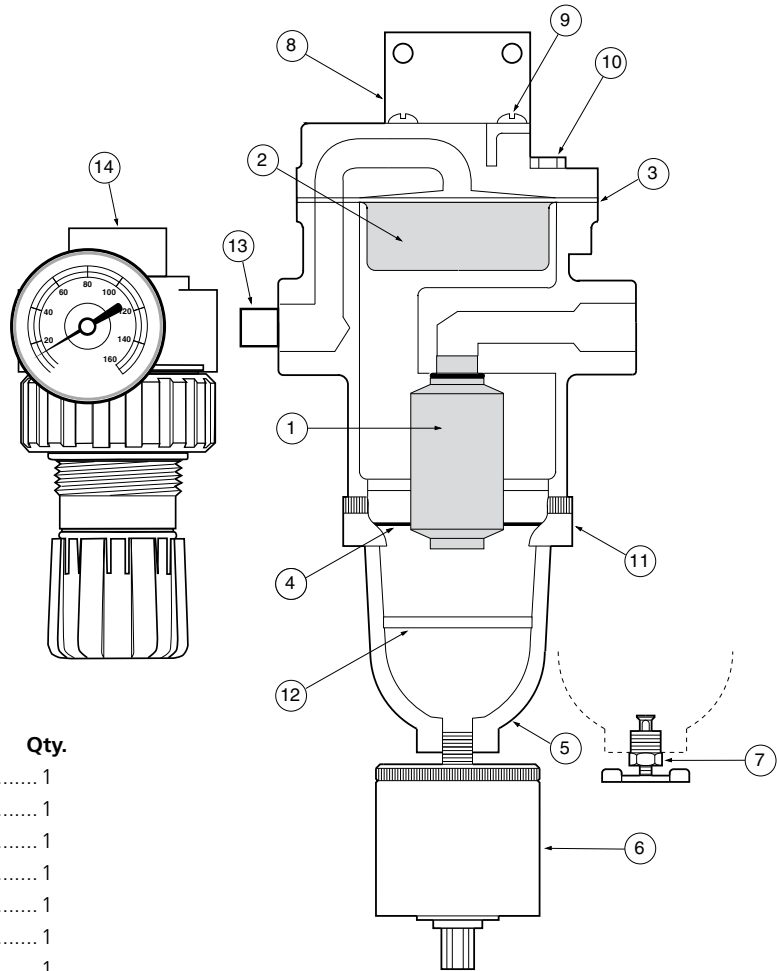

Service Parts List

Item	Description	Part No.	Qty.
1	■ Scrubber Cartridge (1, 2)	above	1
2	■ Polisher Cartridge (1, 2)	above	1
3	■ Gasket	9329	1
4	■ O-Ring	2200-109	1
5	Filter Sump (bronze)	9315B-85	1
6	Auto Drain	2465-36	1
7	Manual Drain Petcock	6120-4	1
8	Mounting Bracket	7624-3	1
9	Bracket Screw	1544S-3	2
10	Housing Bolt	8279-19	4
11	Retaining Ring	9317-11NP	1
12	Baffle	5919-1	1
13	Pressure Gauge (0-160 PSI)		
14	Regulator w/ gauge		

Notes:

- (1) Replacement Set includes items indicated by symbol ■.
- (2) Other cartridge grades are available. Details upon request.



3201 South State St, Ann Arbor, Michigan 48108-1625 U.S.A.
 PO Box 1228, Ann Arbor, Michigan 48106-1228 U.S.A.
 Phone: (734) 662-5691 ■ FAX: (734) 662-6652
www.king-gage.com

© King-Gage and the KE emblem are registered trademarks of King Engineering Corporation, Ann Arbor, Michigan, U.S.A.
 All specifications are subject to change without notice
 © 2005 King Engineering Corporation. All rights reserved