



Effective : May 2008

Ultra-C™ Air Control Station

20 scfm Filter-Regulator-Gauge

Models:

U205 Station w/Automatic Filter Drain

U206 Station w/Manual Filter Drain

Rated Flow:

20 SCFM @ 100 psig

566 l/min @ 7 Kg/cm²

34 m³/hr @ 7 bar

Max. Pressure:

150 psi

Connections:

1/2 in NPT (Input/Output)

Cartridges:

Two (2) Element Design -

1st Stage Scrubber (coalescing)

2nd Stage Polisher (indicates service life by color change feature)

Physical Data:

Housing - Aluminum/Polycarbonate

Weight - 5 lbs.

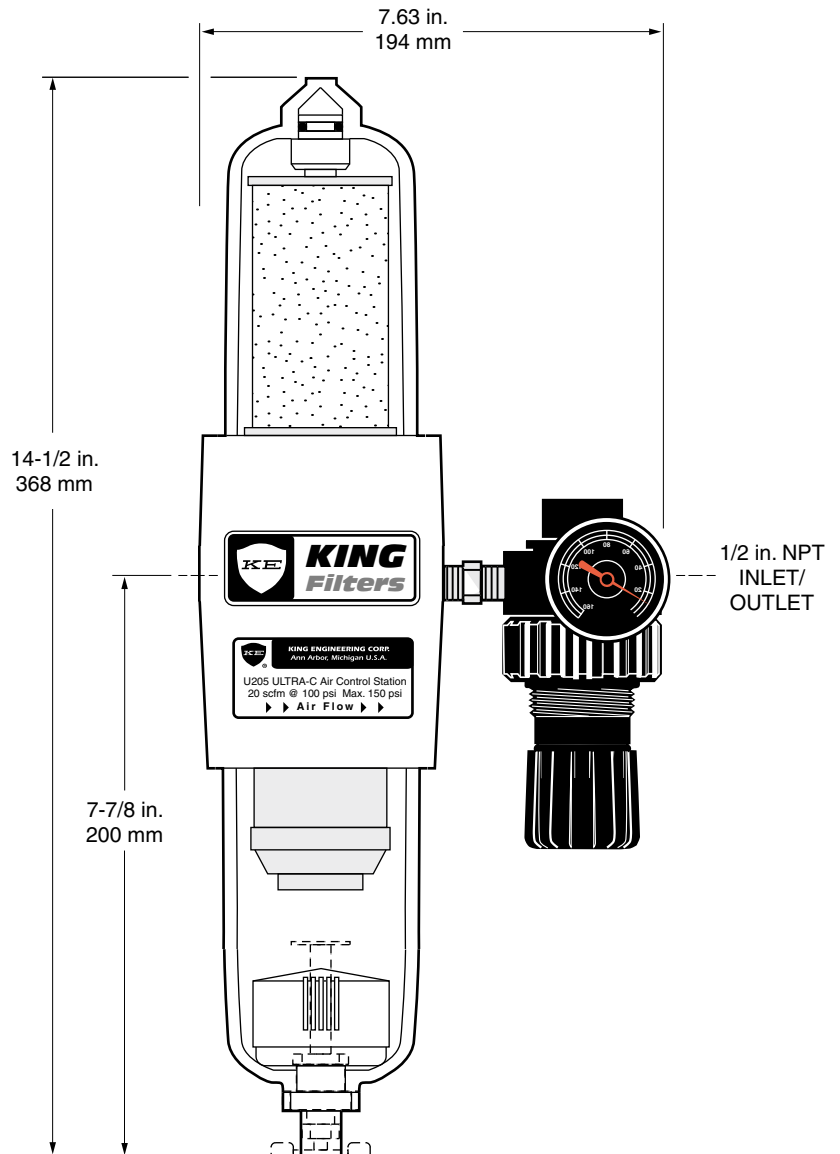

U205/U206
Two Stage Compressed Air Filter
and regulator-gauge

Ultra-C Air Control Station Model U205 or U206

Replacement Filter Cartridges:

Model U205/U206

Lower: 1st Stage Element; Ultra-C U3002
(coalescing type) rated to 0.1 micron

Model U205/U206

Upper: 2nd Stage Element; Ultra-C U3003
(adsorptive color change indicating)
rated to 0.1 micron

Item	Description	Part No.	Qty.
1	Scrubber Cartridge (note 1)	U3002	1
2	Color-Change Polisher (note 2)	U3003	1
3	Bowl Assembly (note 3)	3277-8	1
4	O-Ring (note 4)	2200-155	2
5	Sump w/Auto Drain (note 3,5)	4522-5	1
6	Sump w/Manual Drain (note 3,5)	3277-7	1
7	Manual Drain	6120-4	1
8	Automatic Drain	2465-31	1
9	Regulator with Gauge	7843-2	
	Pressure Gauge (0-160 psi)		

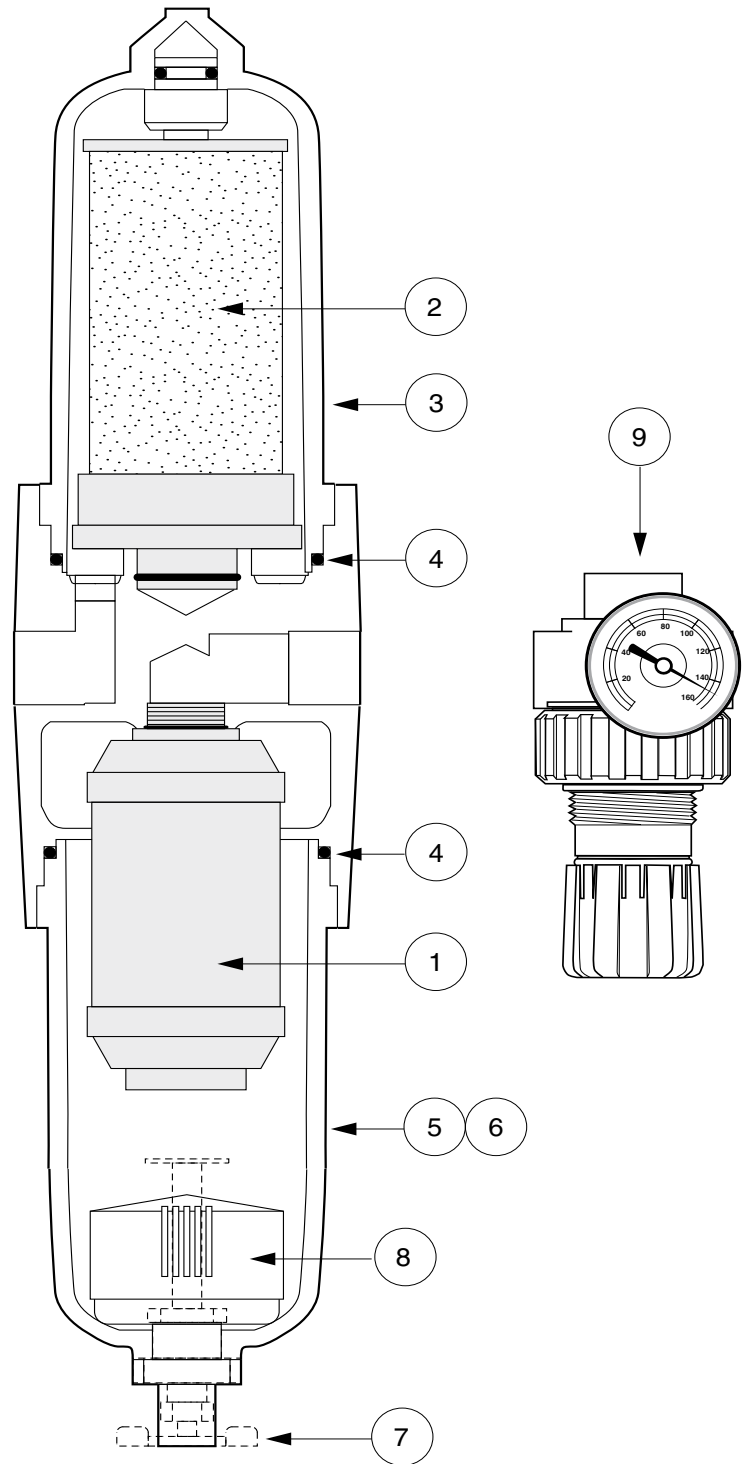

Models U205/U206 Shown.

Notes:

1. Includes o-ring, p/n 6495-12.
2. Includes o-ring, p/n 6495-219.
3. Includes o-ring, p/n 2200-155.
4. Included with items 3, 5 & 6.
5. To replace sump only, order p/n 3277-7.