

KING-GAGE®

Tank Liquid Level

Inventory Monitoring

Process Integration

Downpipe Purge Systems

Downpipe Backflow Check Valve

This engineered component will help you prevent siphoning or backflow of liquid through a downpipe installed in tank level gauging applications. Typically such level measurement employs a continuous air flow to clear the downpipe of liquid with the resulting backpressure equal to the hydrostatic head (depth). However, in the event the air supply is turned off, the loss of air pressure may allow liquid to flow back up the downpipe. This is especially true when the downpipe may be installed through the side of the tank below the point of the tank's maximum depth.

With the KING-GAGE Downpipe Backflow Check Valve, you can guard against liquid traveling up through the downpipe and into the system pressure lines. It utilizes a specially designed float pin that rises up to seal the valve shut when liquid enters from the downpipe through the bottom of the unit. The advantage of a float check is that it doesn't create a pressure drop that would affect the level gauge reading. (Spring-loaded check valves can impact the accuracy of a downpipe or bubbler system if installed at the tank entry point.)

This check valve is not intended to substitute for a shut off or isolation valve for the downpipe into the tank. Not recommended for use with heavy diesel fuel oil or other high viscosity liquids.

Of course, proper placement and installation is important for reliable operation of the Downpipe Check Valve. It is recommended that you install the check valve in an upright position on a vertical portion of the downpipe so that the float will move freely. Do not position the check valve along any horizontal run of the downpipe as it will fail to operate as intended.



Model 6563 Check Valve

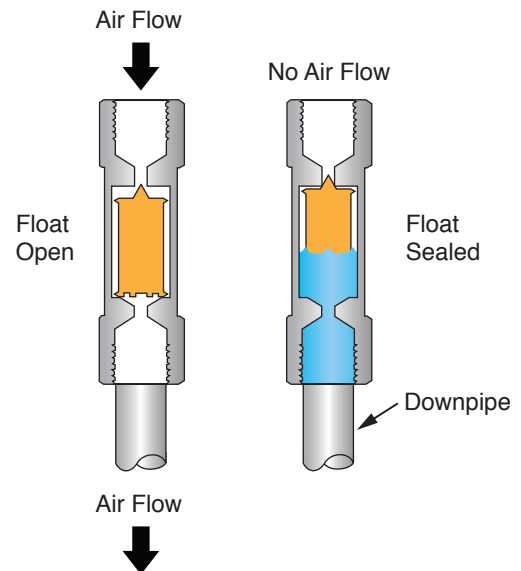

The Model 6563 Downpipe Check Valve is well suited for use on downpipe systems employing KING-GAGE Purge Control or LiquiSeal Purge Control liquid level transmitters. Hydrostatic pressure measurement using a downpipe (also known as a bubbler system) is a proven tank gauging technique that is both accurate and reliable.

EXTERNAL INSTALLATION

Recommended installation of the Downpipe Check Valve is at the top of the downpipe as it exits the tank. (Depending upon the type of tank application and purge control used, this exit may be either at the top of the tank or where the downpipe penetrates through the tank side wall.)

INTERNAL INSTALLATION

When necessary, the Downpipe Check Valve may be installed inline on the internal downpipe of the tank. (This is less desirable due to the difficulty of inspecting or servicing the check valve when installed as such.)

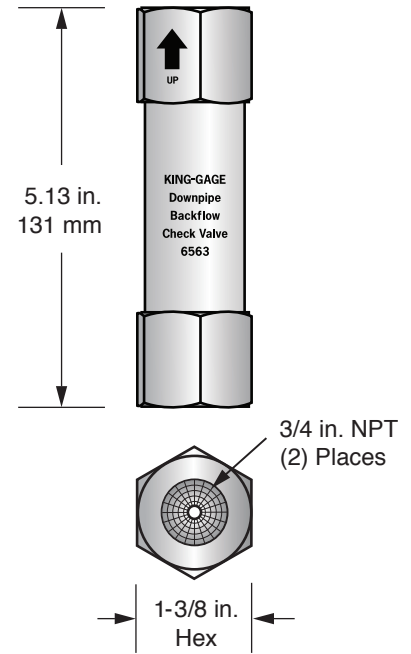

Specifications

- Material:** 304 stainless steel, Nylon (float), Viton (seals)
- Max. Pressure:** 150 psig
- Inlet/Outlet:** 3/4 NPT-female
- Weight:** 1.2 lb (0.5 kg)

