

# **KING-GAGE® Marine Systems**

Tank Level and Draft Indicating Systems for the Marine and Offshore Industries

## **KING Air-Guard™** **20 sfcM Bronze Filter**

- Provides Clean, Dry and Oil-Free Compressed Air
- Long Life Cartridges Reduce Filter Maintenance
- Rugged Bronze Construction for Marine Applications
- Air-Conserving Automatic Sump Discharges Only When Needed

KING Air-Guard Bronze Filters are especially suited to the rigors of marine service. They provide high performance filtration in demanding shipboard compressed air systems. Extremely efficient coalescing action cartridge elements remove both solid and liquid contaminant from the air stream. When equipped with an automatic drain sump, the Air-Guard Filter can handle considerable amounts of oil mist and water condensation typically present in the ship's compressed air supply.

The preferred choice for high efficiency compressed air filtration, KING Air-Guard use a proven 2-stage dual cartridge design. Coalescing action was first introduced by King Engineering over 30 years ago to effectively remove oil, water and particulate from compressed air. While other filters now use this same process, KING Air-Guard filters employ a unique cartridge design that delivers cleaner air longer. Dual cartridges guard against any carryover of contaminants even when the elements reach the end of their service life.

An extremely rugged cast bronze body is a logical choice when corrosive environments preclude aluminum housings. Well suited to the unique rigors of seaside locations or any application where high salinity atmosphere might cause premature deterioration of aluminum housings. The Air-Guard Bronze Filter is a durable alternative when aluminum or plastics are not desirable.



# KING-GAGE® Marine Systems

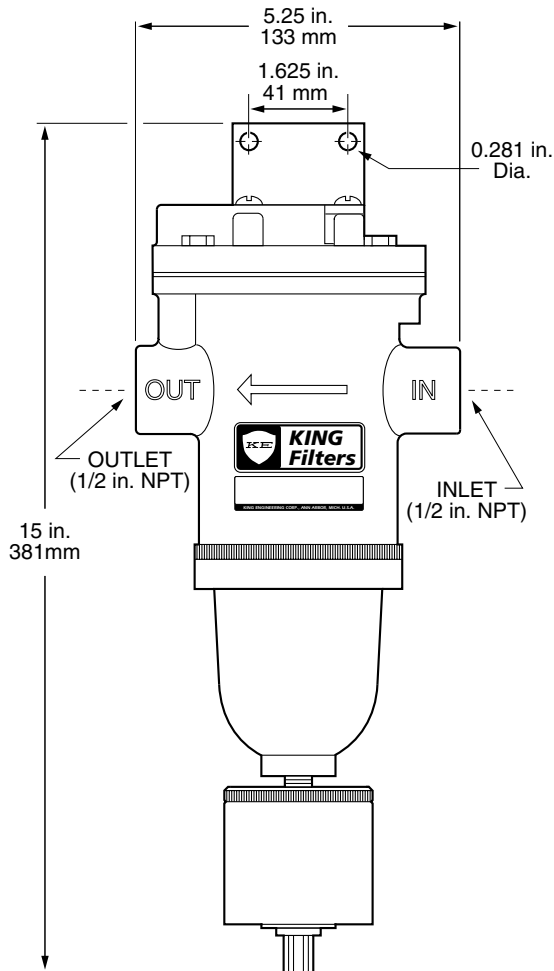

**Air-Guard Filter  
with Automatic Drain  
Model 9313-24T**

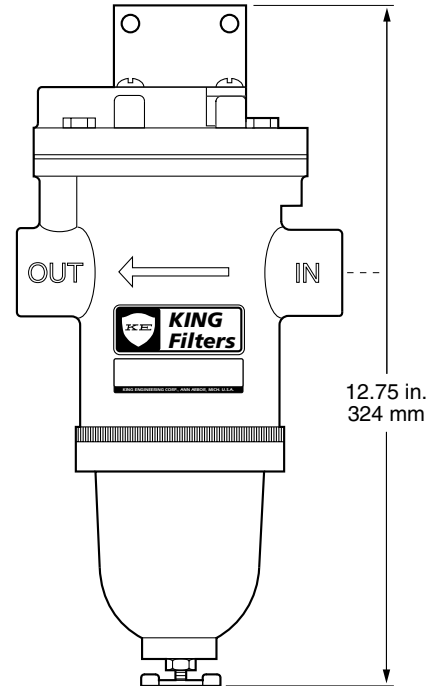

**Air-Guard Filter  
with Manual Petcock Drain  
Model 9313-24**

## Specifications

Model 9313-24T  
with automatic sump drain

Model 9313-24  
with manual petcock drain

**Maximum Inlet Pressure**  
150 psig

**Capacity (Flow)**  
20 scfm @ 100 psig

**Efficiency Rating**  
99.98% of 0.1 micron or greater



3201 South State, Ann Arbor, Michigan 48108 U.S.A.  
PO Box 1228, Ann Arbor, Michigan 48106-1228  
Phone: 734-662-5691 • FAX: 734-662-6652



[www.king-gage.com](http://www.king-gage.com)

© KING-GAGE and the KE emblem are registered trademarks of King Engineering Corporation, Ann Arbor, Michigan U.S.A.

All specifications are subject to change without notice  
© 2008 King Engineering Corporation, all rights reserved.