

Detail 1
860 SafeGard Sensor Control

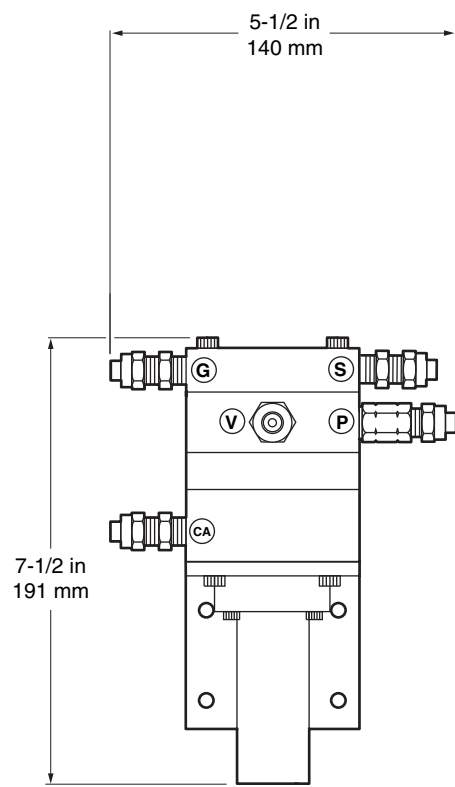

Detail 2
860 Sensor Control

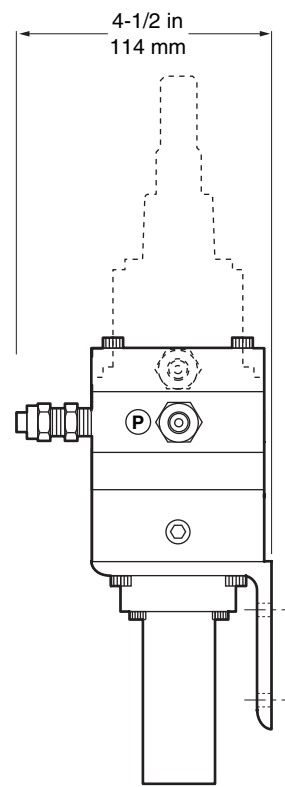

Detail 3
Side View

A. Mounting Sensor Control

Distance from sensing unit at tank to the Sensor Control should generally not exceed 15 feet (length of 3-tube cable supplied with sensing unit, if applicable).

If possible, avoid areas where freezing temperatures may be encountered (refer to "V").

1. Sensor Control must be mounted vertically as shown.
2. Filter drain may discharge water and/or other liquids present in the air supply line during operation.
3. Mounting dimensions are shown for models with and without SafeGard overpressure control. Reference dimensions are maximum based on installed tube fittings.

B. Compressed Air Requirements

Compressed air supply used for the Sensor Control and tank sensing unit must be clean, dry and oil-free. An instrument grade sub-micron rated compressed air filter should be installed in the main air supply line upstream of the feeds to individual Sensor Control(s).

If Sensor Control is mounted where freezing temperatures (32°F/0°C) may occur, compressed air supply must be adequately dry to prevent condensation from icing up the control. Use a compressed air dryer under these conditions.

Caution: Failure to use adequately filtered compressed air will result in poor performance and may void your warranty. A coalescing type compressed air filter with automatic sump drain is specifically recommended.

1. Compressed air supply pressure must be at least 20 PSIG greater than the maximum anticipated liquid head pressure (and any applied blanket pressure, if applicable)- or 35 PSIG, whichever is greater.

Minimum Supply: 35 PSIG

Maximum Supply: 150 PSIG

2. Connect the compressed air supply to the "CA" port of the Sensor Control.

Note: It may be useful to install a shut-off and/or quick disconnect fitting ahead of the "CA" connection to permit removal of the Control for future servicing.

C. Tubing Connections

Sensor Control has 1/4-in. NPT-F threaded connection ports. Fittings, if furnished, are for 1/4-in. O.D. tubing.

1. Install tubing from "P" (purge) connection at tank sensing unit to the "P" port of the Sensor Control.
2. Install tubing from "S" (signal) connection at tank sensing unit to the "S" port of the Sensor Control.
3. Install tubing from "V" (vent) connection at tank sensing unit to the "V" port of the Sensor Control.
4. Connect pneumatic signal tubing to the "G" (gauge) port of the Sensor Control. 1/4-in. O.D. poly tubing is typically used to route the pneumatic pressure signal to a King-Gage Indicator or D/P Transmitter.

Non-Vented Tanks require the following additional connection at the SafeGard Sensor Control only.

5. The "equalizer" or low pressure sensed at the top of the tank must be routed to the "E" (equalizer) port of the SafeGard and then to the indicator. A tee fitting can be installed at the control.

PORT DESIGNATIONS

- CA - compressed air supply inlet
- P - air purge outlet (to tank sensor)
- S - signal pressure (from tank sensor)
- V - vent inlet (from tank sensor)
- G - gauge pressure outlet
- E - equalizer (low pressure) inlet

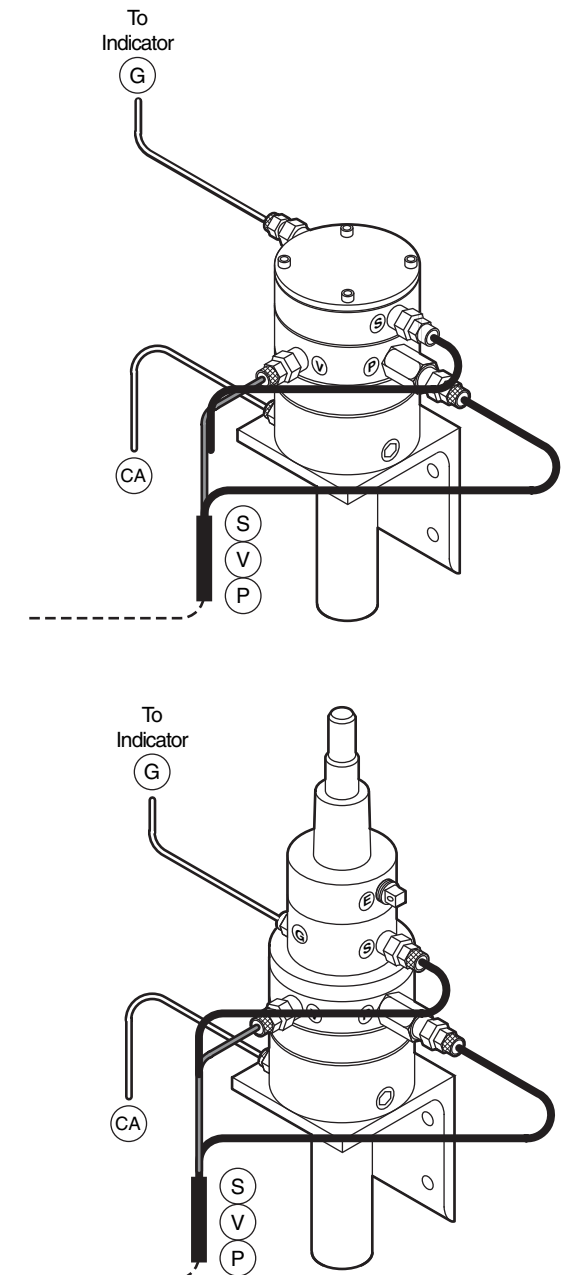

INSTALLATION INSTRUCTIONS

KING-GAGE®

Sensor Control Model No.s

- 860-*9-38 SafeGard Sensor Control
- 860-*9-48 SafeGard Sensor Control
- 860-*9-58 Sensor Control

			DATE	4/16/09
D	4/09	Español		
C	8/97	Redrawn w/ 860-*9-58 Rev	DRAWN BY	<i>[Signature]</i>
			APPROVED	



DWG. NO.	
K-1090-1-860	
SHEET 1 OF 2	REV. D

Controlador de sensor Modelo 860

Se recomienda montar cerca del tanque a no más de 3 metros de la conexión. Se requiere de una conexión de aire comprimido, limpio y seco.

- 1-1. Montar el controlador en la posición indicada. El filtro debe permanecer accesible para su eventual reemplazo (recomendado cada 12 meses). Considere el espacio necesario por debajo del controlador.
- 1-2. Disponga la línea neumática a la ubicación del controlador. Se recomienda la instalación de una válvula para cerrar el suministro de aire y permitir el eventual servicio al controlador.

Presión de Aire

Un filtro de aire coalescente grado instrumental debe instalarse en la tubería neumática. Aire contaminado por humedad o aceite puede afectar el funcionamiento del componente. El suministro de aire debe ser filtrado y suficientemente seco para evitar condensación o congelamiento en el control.

Mínimo: 2.4 bar (o 1.3 bar mayor a la presión de la columna del líquido, la que sea mayor).

Máximo: No exceder 10.3 bar.

Instalación del Sensor y Unidad Controladora

El controlador de sensor es un regulador de aire. Ésta unidad se emplea en conjunto a un sensor neumático de diafragma KING-GAGE montado al tanque. El controlador de sensor genera una señal neumática a un indicador adecuado.

- 2-1. La tubería conectando el sensor en el tanque y el controlador no debe tener la más mínima fuga. (Algunos sensores KING-GAGE incluyen un cable con tres tubos para conexiones neumáticas—ver instrucciones de instalación para el modelo específico de sensor.
- 2-2. Conecte una tubo al puerto "P" de un controlador serie 860 y el sensor en tanque (puerto "P").
- 2-3. Conecte una tubo al puerto "S" de un controlador serie 860 y el sensor en tanque (puerto "S").
- 2-4. Conecte una tubo al puerto "V" de un controlador serie 860 y el sensor en tanque (puerto "V").

Conexión Final de Tubería

Se recomienda tubería 1/4-in. (diámetro externo) para la conexión entre el controlador de sensor y el sensor de diafragma. Las conexiones (si se incluyen) corresponden a las medidas en la lista anexa. No utilizar diversión de aire en ninguna de las conexiones, y no compartir el suministro con ningún componente que no este sellado para evitar fugas de aire.

Indicación

P – Purga
V – Ventilación
S – Señal
CA – Suministro de Aire
G – Señal neumática (indicador)

Conexión

1/4 NPT
 1/4 NPT
 1/4 NPT
 1/4 NPT
 1/4 NPT

Tamaño

tubo de 1/4"
 tubo de 1/4"
 tubo de 1/4"
 tubo de 1/4"
 tubo de 1/4"

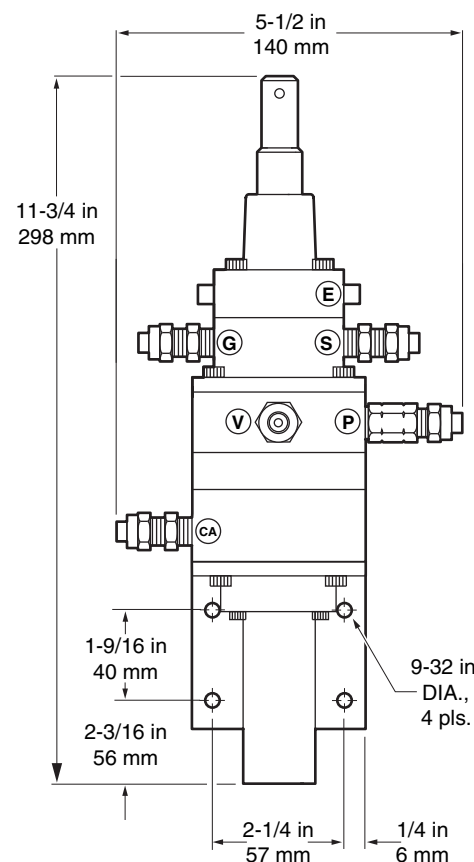

Detalle 1
 860 Controlador de sensor
 SafeGard

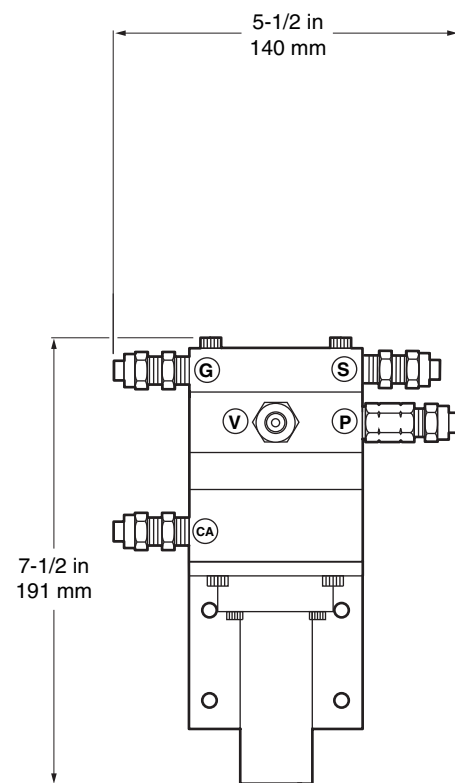

Detalle 2
 860 Controlador de sensor

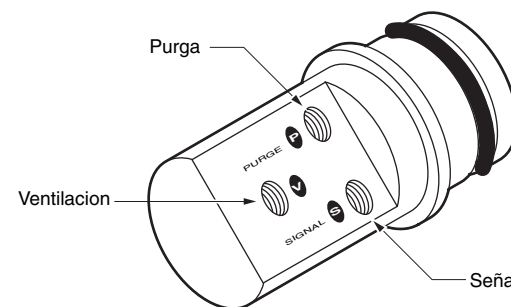
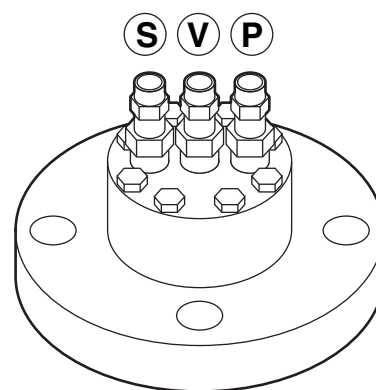

Conexiones del Sensor

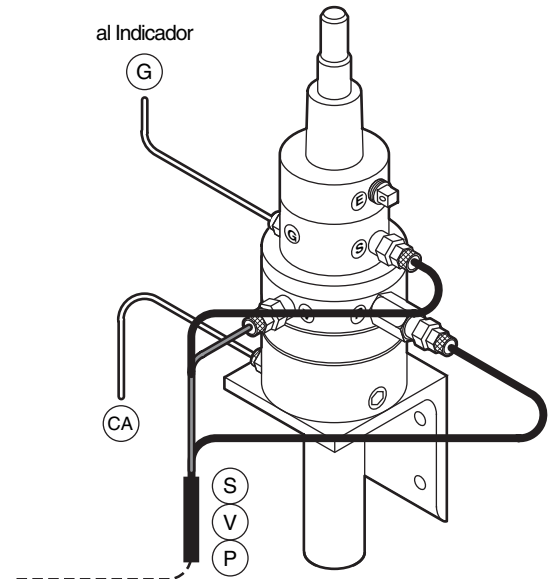
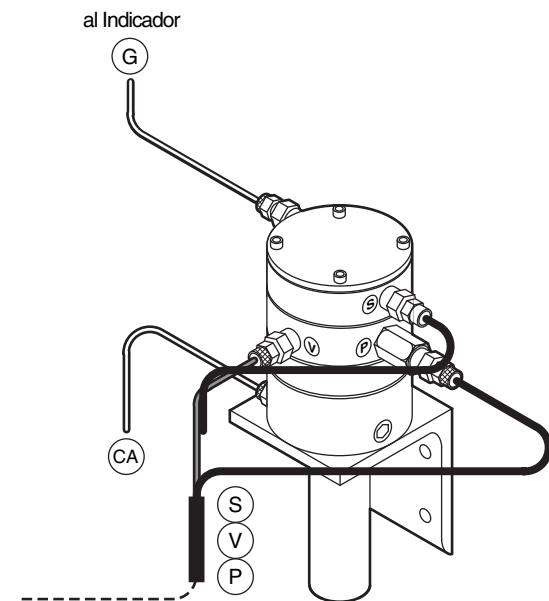

INSTRUCCIONES DE INSTALACION

KING-GAGE®

Controlador de Sensor Modelo No.s
 860-*9-38 Controlador de Sensor SafeGard
 860-*9-48 Controlador de Sensor SafeGard
 860-*9-58 Controlador de Sensor

			FECHA	4/16/09
D	4/09	Español		
C	8/97	Redrawn w/ 860-*9-58 Rev	DIBUJADO POR	
			APROBADO POR	



DIBUJO NO.
K-1090-1-860

HOJA **2** DE **2** REV. **D**