

# **KING-GAGE® ES2**

## **Electronic Liquid Level Transmitter**

### **Installation and Operation Instructions Manual**



**ESR Serial No. Versions  
and Slimline Versions**

© 2011 ATC King Engineering Division. All rights reserved.

The information contained in this manual was accurate at the time of release. Specifications are subject to change without notice.

**Warranty** - All King Engineering products are guaranteed to be free from defects in material and workmanship for one year from the date of purchase. Any product or part found to be defective under normal use within one year of purchase will be repaired or replaced at no charge if returned to the company at Ann Arbor, Michigan within ten days of discovery of the defect. No other warranties, whether expressed, implied, or statutory, including the warranties of fitness for a particular purpose or merchantability, are given by this agreement.

The exclusive remedy for nonconformity of these goods shall be repair and/or replacement of the nonconforming goods or parts.

Seller will not be liable for consequential damages resulting from breach of this agreement. The term "consequential damages" shall include but shall not be limited to damage to all machines, equipment and goods other than the goods sold hereby, interruption of production, loss of profits, delays of any kind, administrative expense and overhead.

**Revisions:**

- (A) March, 2008 – Original Release (applicable to ESR- serial no. versions)
- (B) August, 2008 – Illustrations based on encapsulated board (ESR-serial no. versions)
- (C) May, 2009 – molded cable w/ M12 plug connector
- (D) August, 2009 – revised span adjustment ranges
- (E) November, 2009 – ES2 Slimline version added
- (F) August, 2011 – revised remote junction notes

## Table of Contents

Specifications .....	4
Model No. Designations .....	5
Mounting Dimensions .....	6–8
Typical Application .....	9
Power Requirement .....	10
Connectors and Signal Cable .....	10–11
Test Point Terminals .....	12
ES2 Calibration .....	13–14
Remote Junction Enclosure (optional) .....	15
Calibration Equipment Setup .....	16
Calculating Milliamp Output .....	17
Service Parts and Replacement .....	18–19

# ***KING-GAGE ES2***

## **Level Transmitter**

Two-wire transmitter provides a direct 4-20 mA<sub>dc</sub> analog electronic output signal. The ES2 transmitter is designed specifically for hydrostatic pressure measurement for liquid level gauging.

### **Specifications**

#### **Pressure Ranges**

0-5, 0-10, 0-15, 0-30, 0-50 psig  
(Gage pressure measured relative to ambient atmospheric pressure.)

#### **Accuracy**

Less than  $\pm 0.20\%$  FS  
Includes linearity, hysteresis, non-repeatability errors.

#### **Pressure Media**

Gas or Liquids compatible with 316 stainless steel (diaphragm);  
silicone rubber (O-ring). All other wetted parts 316L.

#### **Electrical**

Input (excitation): 14-40 V<sub>dc</sub>  
Output (mA<sub>dc</sub>): 4-20 milliamperes

#### **Span Adjustment Range**

Transmitter adjustment turndown is 3:1 for the 0-15, 0-30, 0-50 psig nominal ranges.

<i>Nominal</i>	<i>Minimum</i>	<i>Range of Adjustment</i>
0-5 psig	0-3 psig	0-83 in. thru 0-138 in. water/0-2.1 m thru 0-3.5 m water
0-10 psig	0-3 psig	0-83 in. thru 0-277 in. water/0-2.1 m thru 0-7.0 m water
0-15 psig	0-3 psig	0-83 in. thru 0-415 in. water/0-2.1 m thru 0-10.5 m water
0-30 psig	0-10 psig	0-277 in. thru 0-830 in. water/0-7.0 m thru 0-21.0 m water
0-50 psig	0-15 psig	0-415 in. thru 0-1384 in. water/0-10.5 m thru 0-35.1 m water

#### **Operating Limit (Maximum Pressure)**

Pressure above 300% nominal range (overrange) will result in damage to the transmitter  
(200% may cause a shift in calibration).

#### **Non-Repeatability (Worst Case)**

Less than 0.02% FS

#### **Operating Temperature Range**

0°F to 175°F/ -17°C to 79°C

### Range Designation

The last two digits of the model number actually refer to the transmitter range. As an example, MODEL 5502-3-10 is a 0-10 psig range transmitter.

### Model No. Designations

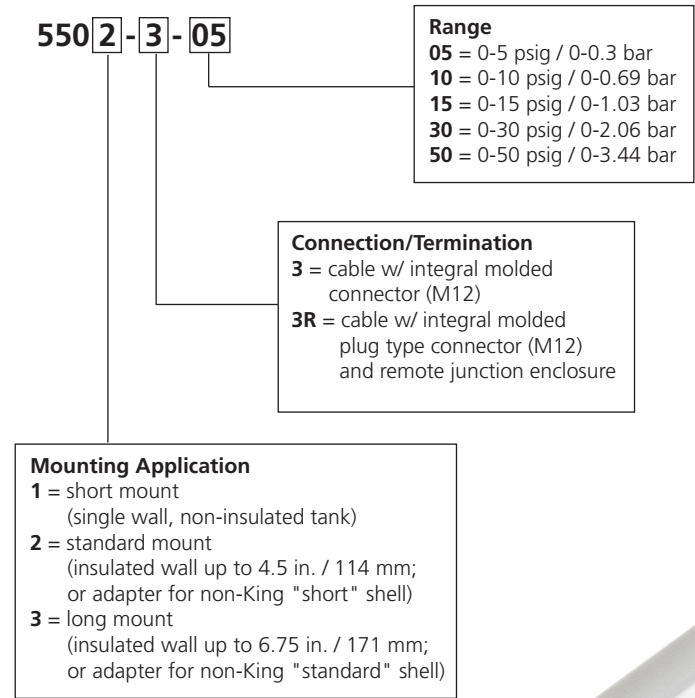

**Slimline Versions**



**ESR Serial No. Versions**

### Mounting Dimensions

Mounting dimensions are shown for both the newer "slimline" design and existing ES2 transmitter housings. From an application standpoint, there are three (3) models designations that specify overall mounting length. Allow

adequate clearance for installation and removal of the transmitter. Clearance dimensions will vary depending upon type of cable or connector used.

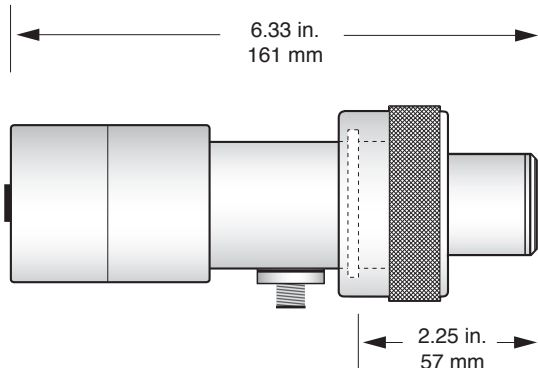

**Model 5501 ES2 Slimline Transmitter - Short Mount**

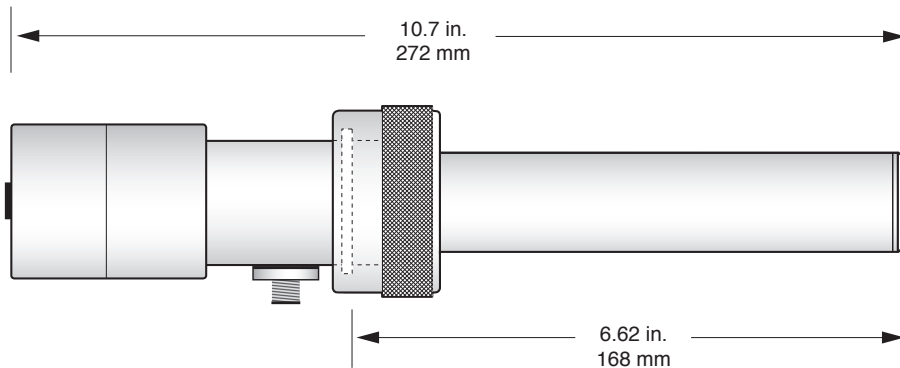

**Model 5502 ES2 Slimline Transmitter - Standard Mount**

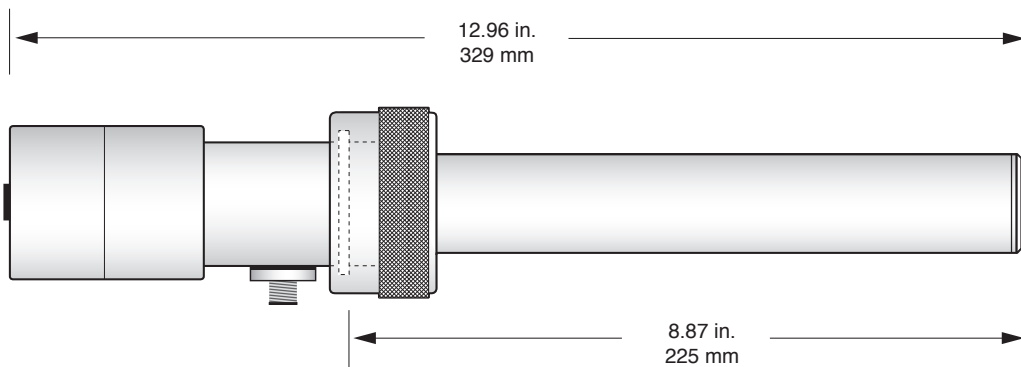

**Model 5503 ES2 Slimline Transmitter - Long Mount**

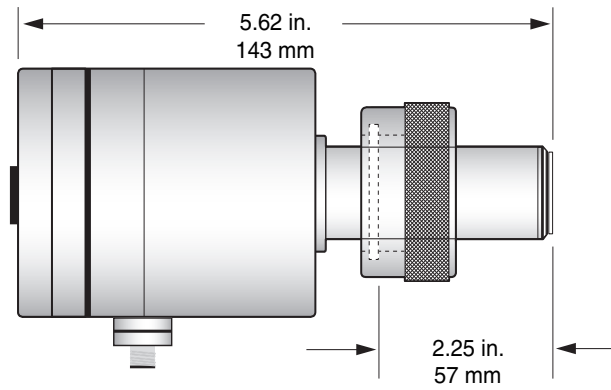

**Model 5501 ES2 Transmitter - Short Mount**

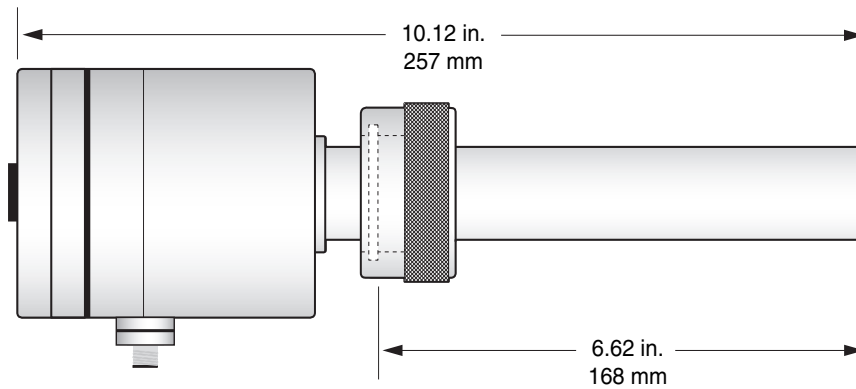

**Model 5502 ES2 Transmitter - Standard Mount**

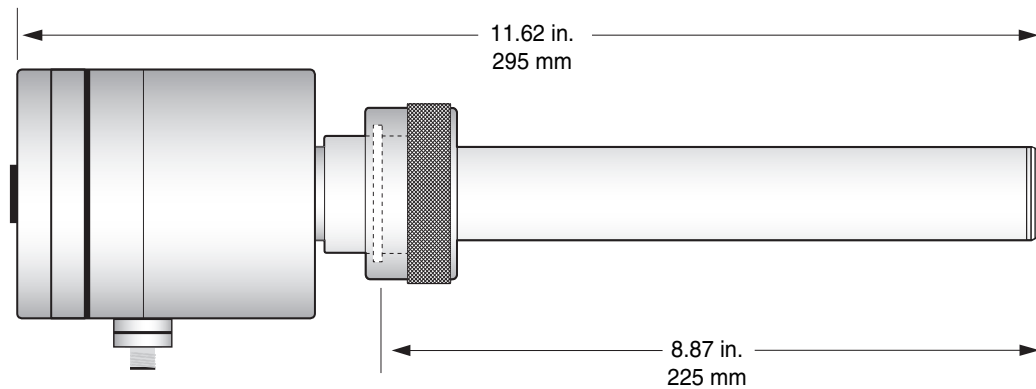

**Model 5503 ES2 Transmitter - Long Mount**

### End View Mounting Dimensions

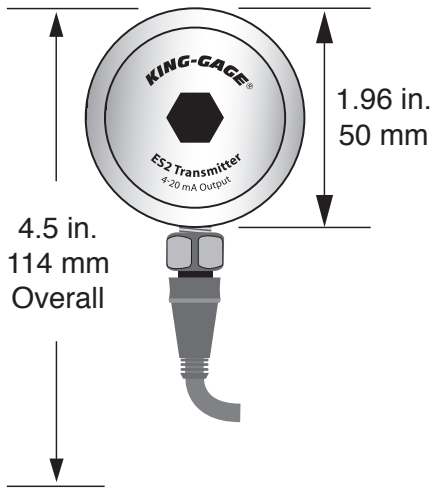

ES2 Slimline Transmitter shown with M12 plug-in Molded Cable Assembly

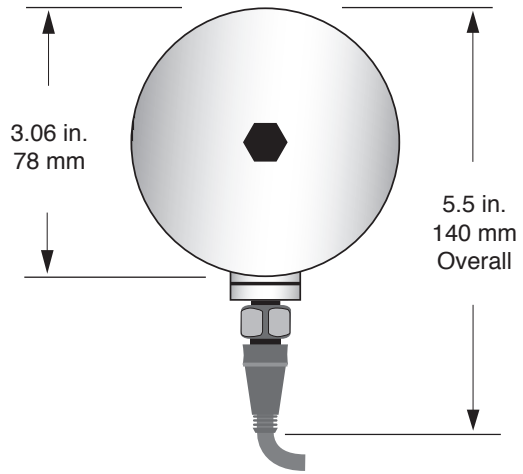

ES2 Transmitter shown with M12 plug-in Molded Cable Assembly

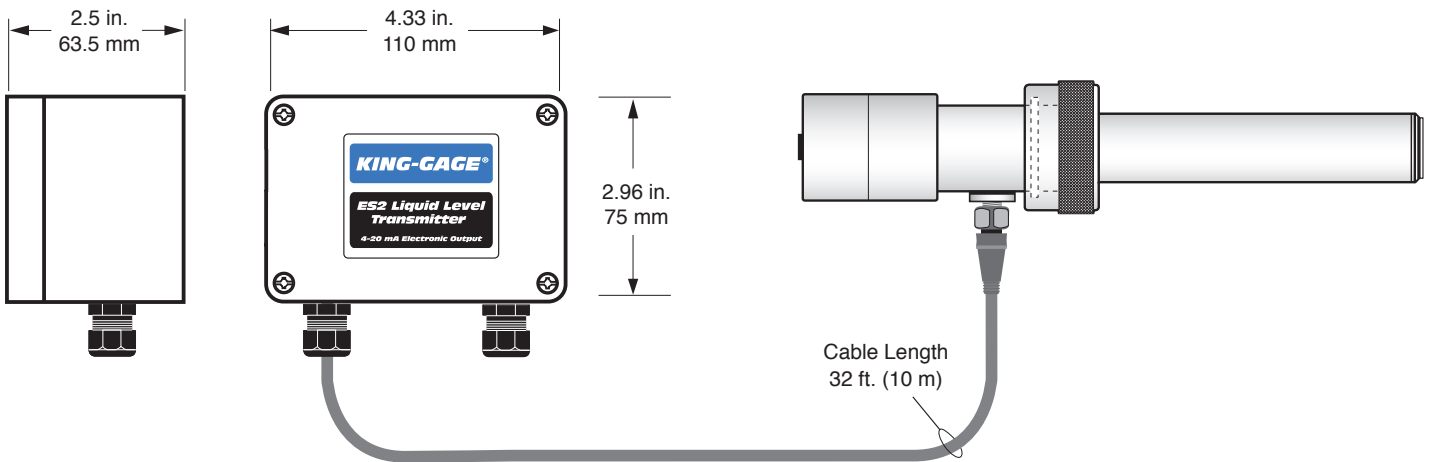

ES2 Optional Remote Junction Enclosure with Molded Cable Assembly



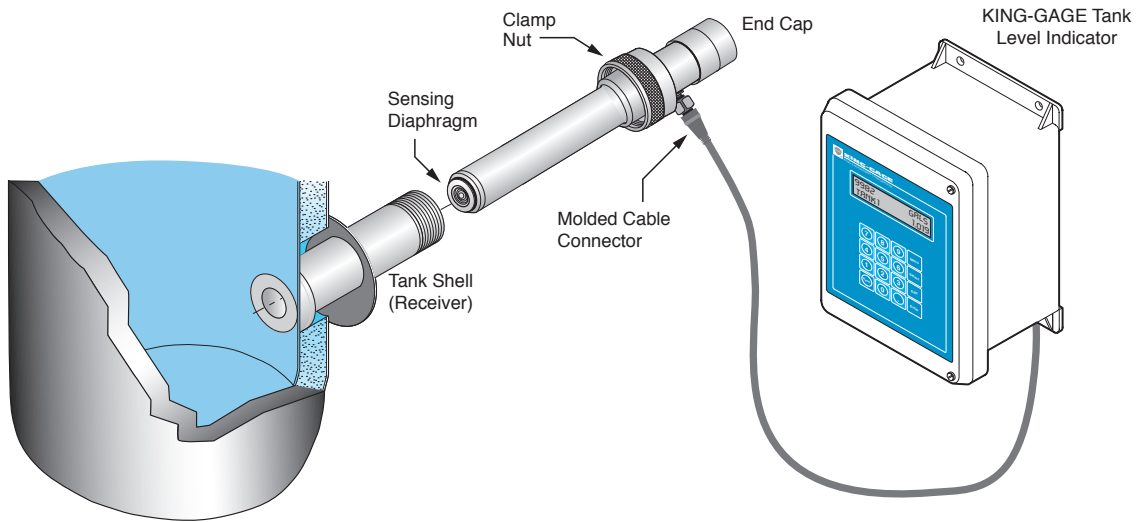

**ES2 Liquid Level Transmitter Application**  
(typical system with tank level indicator)

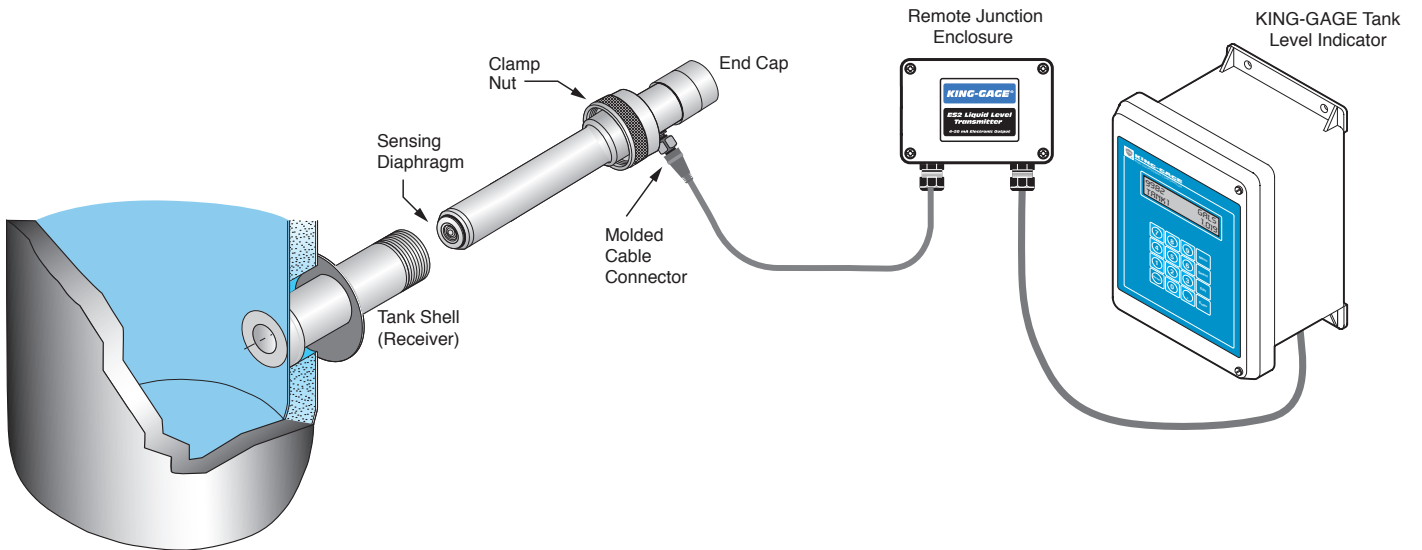

**ES2 Liquid Level Transmitter with Remote Junction Enclosure**  
(typical system with tank level indicator)

**Power Requirement (14–40 Vdc)**

The ES2 transmitter requires a source of DC power for operation. Minimum excitation voltage must be no less than 14 Vdc. Any receiver installed on the signal loop (meters, data loggers, controllers, etc.) must be taken into account when determining the required power supply voltage to be used. The internal resistance of each device added together represents the total “load” residing on the signal loop circuit.

$$\text{Load Capacity} = \frac{(\text{Supply Voltage} - 14)}{(\text{OHMS}) \cdot 0.02}$$

**Load Capacity at Supplied Voltage**

20 Vdc	24 Vdc	28 Vdc	32 Vdc
300 ohms	500 ohms	700 ohms	900 ohms

KING-GAGE® tank processors and LevelBAR provide 24 Vdc excitation to power the signal loop circuit. (If the application requirement exceeds 500-ohms, an external power supply of appropriate voltage will be required.)

**ES2 Signal Connection**

The external connector of the ES2 transmitter affords an impermeable barrier against moisture infiltration of the transmitter housing. This connector receptacle has a metric M12 screw collar and is intended for plug type molded cable assemblies designed for 4-pole signal termination. Our ES2 transmitter package also includes a molded M12 cable (32 ft/10 m) to simplify installation and ensure a sealed connection at the unit—this molded cable meets IP68 standards for ingress protection.

NOTE: Avoid installing sensitive measuring equipment, or wire carrying low level signals, near sources of electrical and magnetic noise, such as breakers, transformers, motors, SCR drives, welders, fluorescent lamp controllers, or relays. Use twisted pair wiring to reduce magnetic noise pickup. Never run signal-carrying wires in the same conduit that carries power lines, relay contact leads, or other high-level voltages or currents.

The signal output is transmitted through 4-20 mA current loops that are low impedance electric circuits. Long cabling runs can increase the susceptibility for higher levels of noise to be transferred to the current loop circuit. Also, intermittent EMI or RFI with a changing frequency or intensity may induce interference on the transmitted output signal.

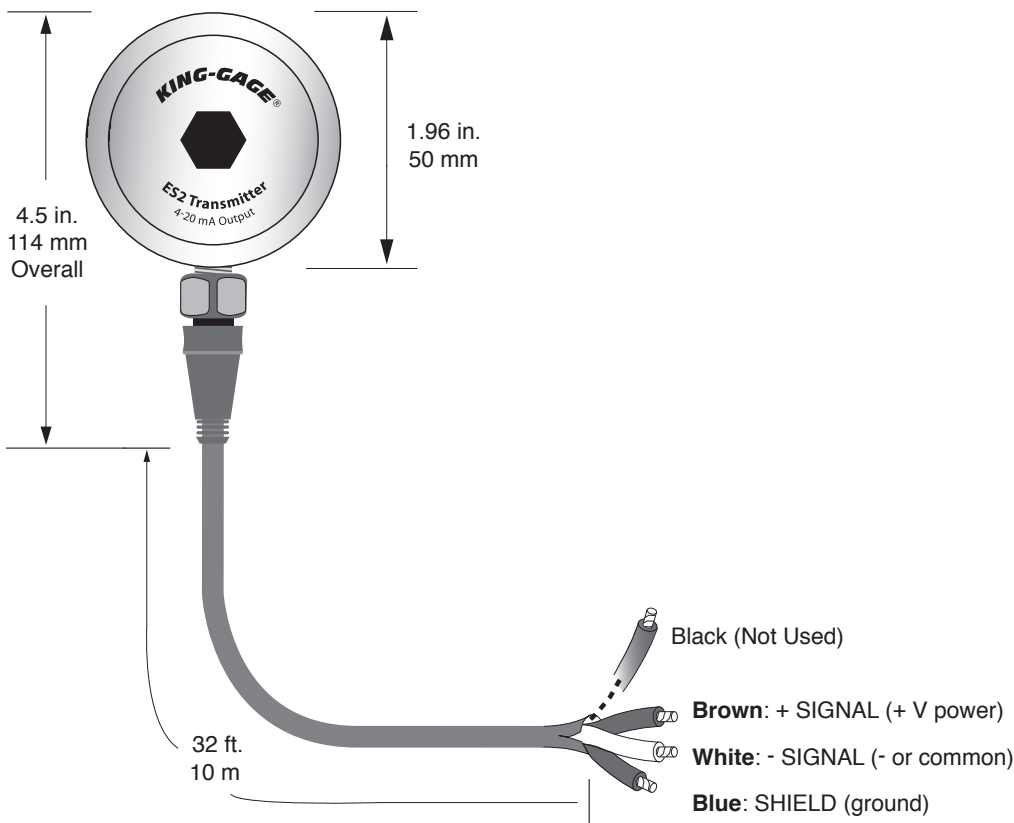

## Optional Field Wiring Connector



Part No. 5378-2-1

Refer to the diagram to access the field wiring terminals of the connector assembly. The connector body incorporates four (4) terminals – however, only two (2) terminals are used for the 4-20 mA signal loop with an additional connection for shield/ground. There may be numbers molded into the connector body specifying the PIN designations.

### Signal Cable

Please follow the installation instructions carefully to ensure that the connector assembly is adequately sealed to prevent corrosion of the field wiring terminals. This is especially critical when stripping back the cable sheath. We strongly recommend that cable be 20-22 AWG.

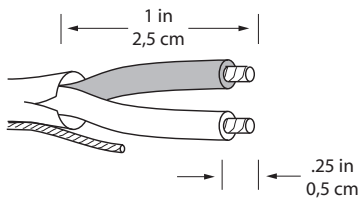

1. Strip back 1" (2.5 cm) of the outer cable sheath.
2. Strip back 1/4" (0.5 cm) of the insulation on each of the two conductors.

NOTE: Cat 5e cable is composed of four pairs 24 AWG stranded conductors and not suggested for use when wiring the transmitter.



### Field Wiring Connector Assembly & Connector Body Detail

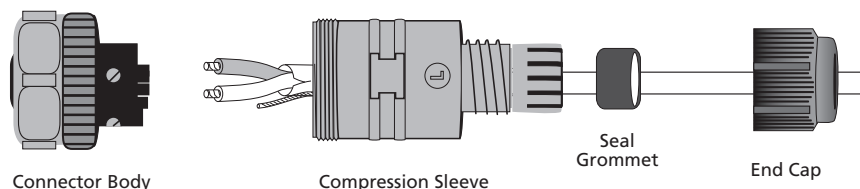

### Transmitter Signal Cable

Use twisted pair cable (20-22 AWG) for the signal loop between transmitter and receiver.

#### Recommended Signal Cable

Unshielded twisted pair cable (UTP), 20-22 AWG  
*Example: Belden 9407*

3. The connector body employs screw clamping terminals that require a small blade screwdriver. (Note that screws have been removed from the two unused terminals.)
4. Connect the positive + signal to PIN 1 (brown).
5. Connect common or negative – signal to PIN 2 (white).
6. Connect shield or ground (if applicable) to PIN 3 (blue).

### Assemble and Seal Connector

7. Make certain that the field wiring cable passes through the seal grommet and end cap.
8. Hand-tighten the compression sleeve until snug.
9. Hand-tighten the end cap until snug. Use a wrench to tighten an additional 1/2 turn.
10. Plug completed connector assembly into the external receptacle on ES2 housing (it is keyed for proper orientation). Hand-tighten the stainless steel connector nut onto the receptacle.

**Test Point Terminals (TP2, TP3)** – Test meter terminals are provided within the transmitter housing on the lower portion of the printed circuit board (see diagram) for measuring the output signal without disturbing the signal loop. Do not connect any device or meter whose internal resistance exceeds 20 ohms across these test points. Also refer to “In-Process Zero/Span Adjustment” in the following section.

Test Meter Posts are visible just below zero and span potentiometers (see illustration).

- **signal** (TP2; below span pot)
- + **signal** (TP3; below zero pot)

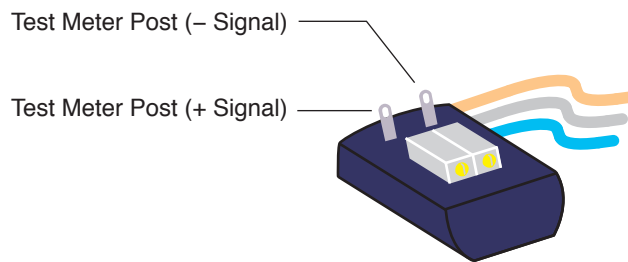
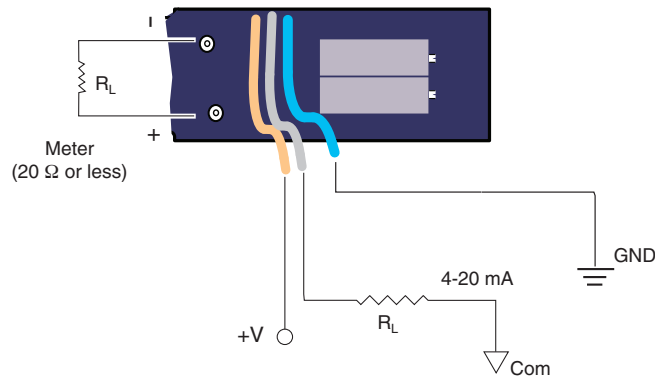

### ES2 Calibration – Zero/Span Adjustment

This procedure is intended to recalibrate the existing zero and span output settings. It is generally recommended that the zero output be checked at least every 12 months. Generally speaking, slight adjustment of the zero potentiometer is all that is needed to maintain transmitter accuracy. However, since zero is an offset adjustment, shifting this setting upward or downward will have some corresponding effect on span.

#### Adjusting Zero Setting

Check zero by measuring the output using the test meter posts on the transmitter board.

- 1-1. Adjust zero potentiometer as necessary to increase output (clockwise) or decrease output (counterclockwise) until the signal displays as 4.00 or 4.01 mA on the test meter.

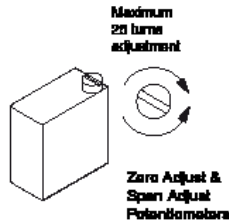

#### Adjusting Span Setting

This requires applying pressure to the face of the ES2 sensing diaphragm equivalent to the maximum depth (hydrostatic) pressure. Measure the output using the meter terminal posts on the transmitter board.

- 1-2. Adjust span potentiometer as necessary to increase output (clockwise) or decrease output (counterclockwise) until the signal displays as 20.00 or 20.01 mA on the test meter.
- 1-3. Next step is to re-check the zero output and slightly adjust if necessary.

#### In-Process Zero/Span Adjustment

It is possible to make adjustments to the zero setting while the ES2 transmitter is installed at the tank. The meter terminal posts permit in-process monitoring without disturbing the loop wiring. Confirm that the tank is empty (or liquid level is below sensor). Measure the transmitter output using a milliammeter and adjust zero potentiometer as required.

**Using Multimeter:** Set multimeter for DC current, using mA or .001 amp scale. The internal resistance of the meter must be 20 ohms or less since higher resistance values will create incorrect readings. Connect the leads to the meter posts on the internal circuit board.

Adjusting span settings of an installed transmitter is not a very precise method for calibration (since the hydrostatic pressure may not be accurately determined). For this reason, in-process span adjustment is not recommended.

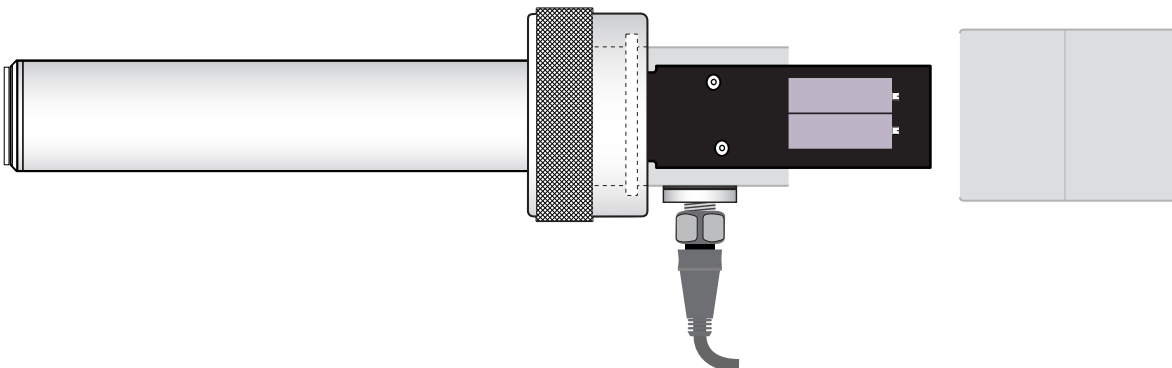
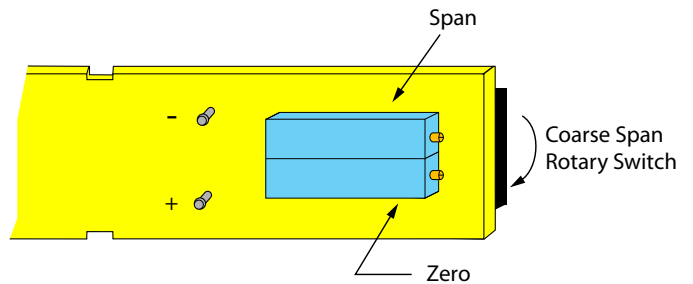
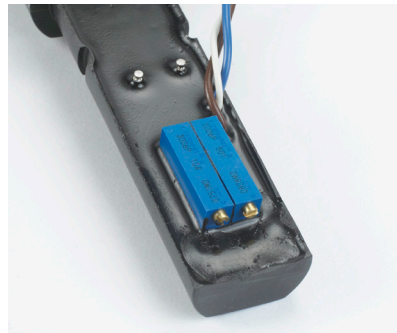

## ES2 Range Adjustment Rotary Switch Settings

The ES2 transmitter span can be turned down from the nominal range indicated by the model number. (Refer to "Span Adjustment Range" under Specifications on page 2.) This is how the transmitter's pressure range can be reduced for a specific application.

### WHEN NOT TO CHANGE SPAN

If a KING-GAGE indicator is part of the system, you should not have to change the range (span) of the transmitter.

When the ES2 transmitter is used with a KING-GAGE digital tank level indicator, the "Application Datapack" (iButton memory module) is generally programmed with the nominal range setting. The indicator programming will correlate the output signal to tank capacity regardless of whether the maximum tank level generates less than 20.00 mA output from the transmitter.



### Coarse Range Setting

An initial coarse range setting is provided by the rotary switch. Use the previously outlined Zero/Span Calibration to achieve the final trim setting for precise 4.00-20.00 mA output over the intended pressure range.

The Span Ranging rotary switch on the transmitter circuit board affects the span (range) of the transmitter and can be used in addition to the fine span adjustment of the potentiometer.

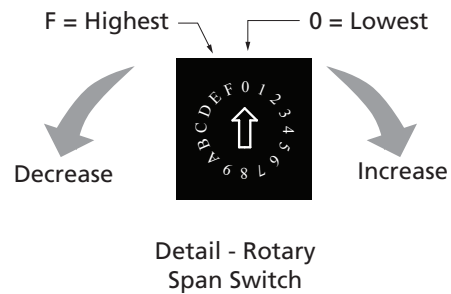

The rotary switch provides 16 increments of coarse adjustment. Prior to changing the switch setting, check the current output of the transmitter at the desired upper pressure value. Also note the existing switch setting.

- 2-1. Apply the desired maximum pressure to the sensing diaphragm of the ES2 transmitter (requires a pressure test shell available from King Engineering).
- 2-2. Record the existing setting position of the rotary switch.
- 2-3. Adjust the potentiometer to maximum output by turning clockwise until it "clicks".
- 2-4. To increase the milliamp output, use a higher switch setting; to reduce the milliamp output, use a lower setting. (The goal is to achieve a output signal value just slightly above 20 milliamps and then use the potentiometer to trim the setting.)
- 2-5. Follow the Zero/Span Calibration procedure to check both the zero and span output.

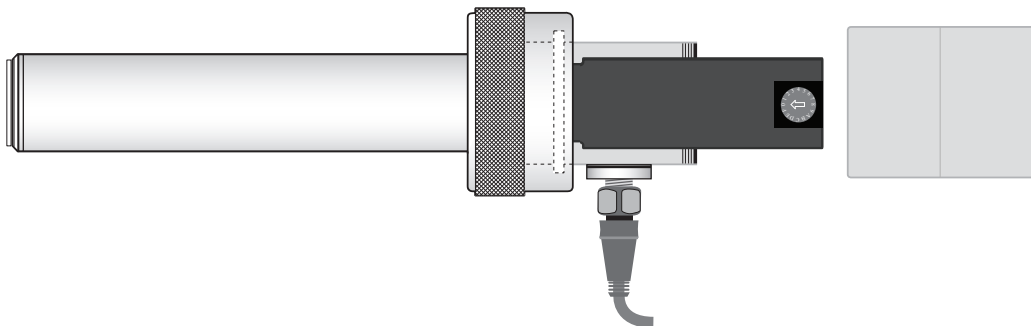

## ES2 Optional Remote Junction Enclosure – Signal Loop Connection Terminals

### Supplied Cable and Enclosure

The supplied cable includes a molded plug connector that mates to the M12 receptacle of the ES2 transmitter housing. Note that only 3 conductors of the cable are used to terminate within the junction enclosure (BROWN +, WHITE -, BLUE Shield/Gnd). The remote junction enclosure provides screw clamp type terminals for the external signal loop wiring and isolated test meter terminals. Entry points at the junction enclosure are provided with watertight cord grip fittings for the sensor cable and external signal transmission wiring.

When supplied with the remote junction enclosure, the molded cable assembly is connected to the receptacle provided on the ES2 transmitter housing. Signal loop connections are now conveniently extended to the junction enclosure (standard cable length is 32 ft/10 m). Open the enclosure to reveal the screw clamp type wiring terminals +/- Signal for connecting twisted pair cabling from the tank level indicator or remote receiver.

ALWAYS USE THE TEST POINT TERMINALS within the remote enclosure when checking the signal output or making adjusting the zero setting of the transmitter. Test point terminals are provided within the junction enclosure for use with a multimeter. These are located at the top edge of the card and labeled as “- 4-20 mA +” (they are designed to easily accept the clip type leads used with a handheld meter).

### Adjusting Zero (Remote Enclosure)

Refer to “Adjusting Zero Setting” on page 13.

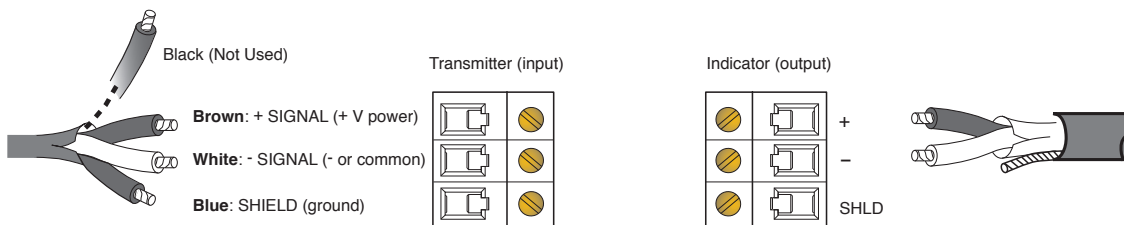
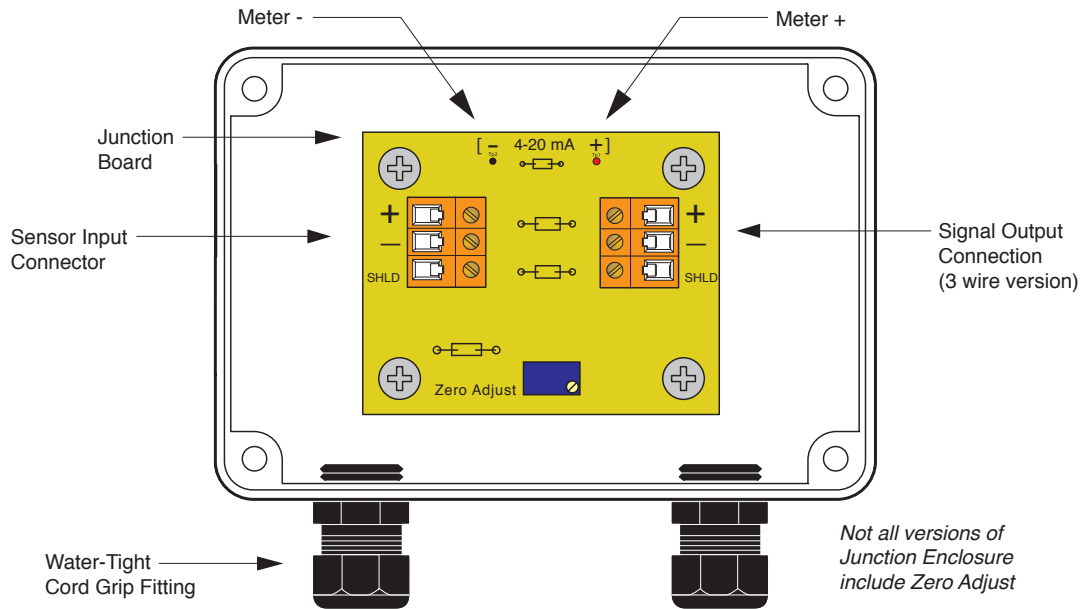

### Calibration Equipment Setup

To ensure specified accuracy during field calibration, the equipment and setup used must conform to the minimum requirements noted in this section.

**Milliammeter (multimeter):** 3-1/2 digit minimum, 0.05% accuracy (internal resistance 20 Ohms or less)

**Power Supply:** 24 Volts DC (regulated); permissible range is 14-40 Vdc

**Pressure Indicator:** 0.05% accuracy (corresponding to transmitter nominal range)

- 0-5 psig + 0.0025 PSI (or 0.07 in. of water)
- 0-10 psig + 0.0050 PSI (or + 0.14 in. of water)
- 0-15 psig + 0.0075 PSI (or + 0.21 in. of water)
- 0-30 psig + 0.0150 PSI (or + 0.42 in. of water)
- 0-50 psig + 0.0250 PSI (or + 0.69 in. of water)

**Pressure Regulator:** High precision fine thread adjustment for stable air/gas pressure application

CAUTION: Some pressure regulators will allow a slight pressure output even when completely adjusted to the shut position. It is preferable to vent the transmitter to atmosphere by disconnecting the pressure input to ensure accurate zero setting of transmitter.

### Test Shell Fixture

This pressure fixture is available in the following configurations based on the mounting length of the ES2 transmitter. Threaded 1/8 NPT connections permit air/gas pressure to be applied to the face of the transmitter when seated within the test shell.

Part No.	Applicable Transmitter Model
5668-1	short mount ES2 Model 5501-x-xx
5668-2	std mount ES2 Model 5502-x-xx
5668-3	long mount ES2 Model 5503-x-xx

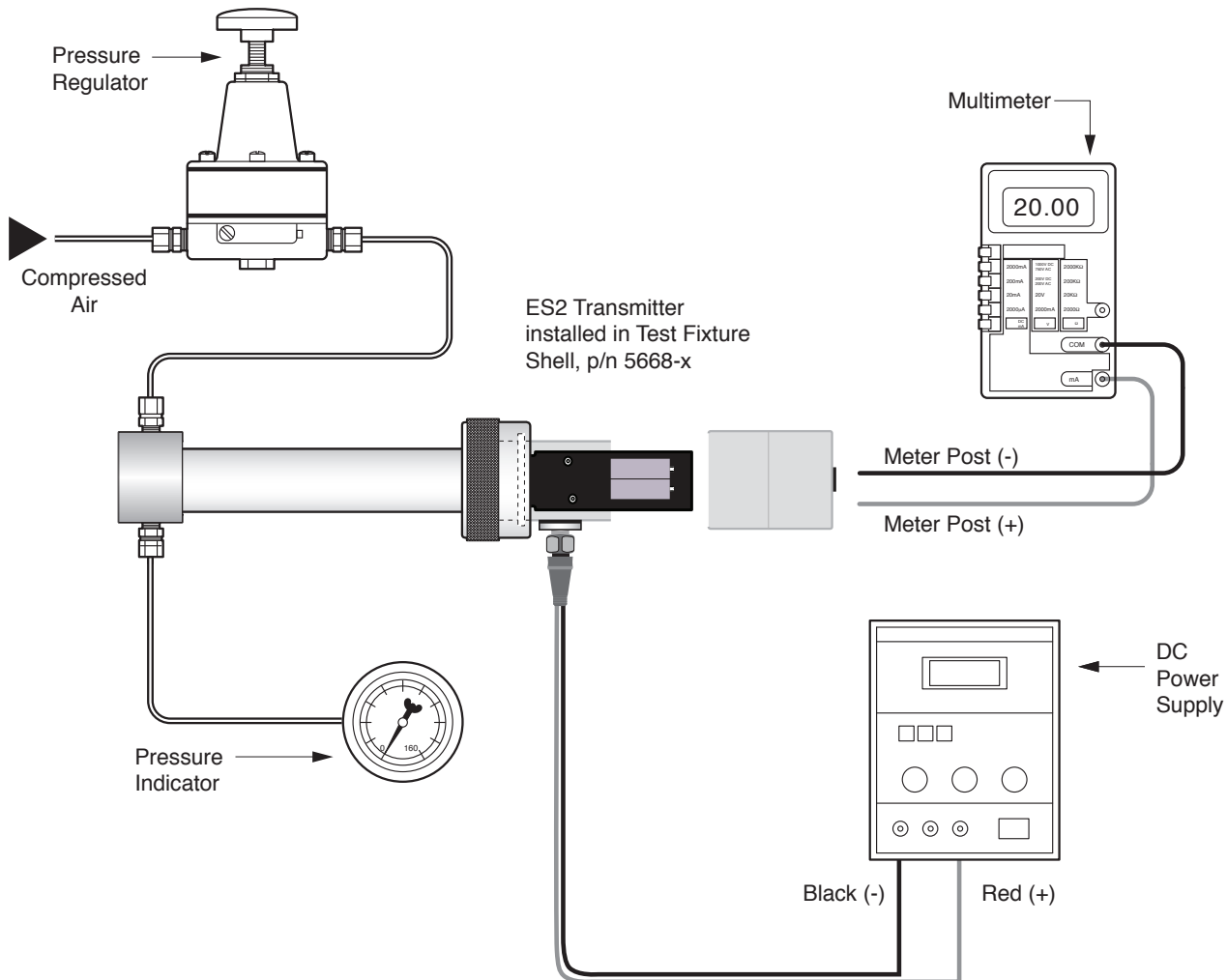



## Calculating Milliamp Output

### When Output will be Less Than 20 mA...

#### ■ Maximum Pressure Below 3.00 PSI

When the nominal 5 PSI transmitter is used on an application whose maximum pressure is less than 3.00 PSI, the full calculated range output will be less than 20 mA. To determine the actual milliamp output of the transmitter when the maximum applied pressure is below the lower span limit, use the following formula:

$$\frac{(16 \times \text{Calculated PSI})}{3.0} + 4 = \text{mA Output}$$

The King-Gage® ES2 transmitter is factory-calibrated to nominal range only. Unless span is adjusted for a specific calculated pressure range, the milliamp output of the sensor at full tank level will generally be less than 20.00 mA.

Actual output can be calculated based on total tank depth and specific gravity of the liquid product:

$$\frac{(B - A) \times C}{27.6807} = \text{Tank Pressure}$$

where...

- A** = Reserve (inches of depth from low point of tank to sensor)
- B** = Full Tank (inches of depth from low point of tank to full)
- C** = Specific Gravity of Tank Contents

Now, using the calculated tank pressure from above, the actual milliamp value at full can be determined:

$$\frac{(16 \times \text{Tank Pressure})}{\text{NOMINAL psig RANGE}} + 4 = \text{mA Output}$$

(NOTE: If the span setting is turned down from the nominal range, refer to the calculation for determining milliamp output.)

### Example - mA Output Calculation for Tank Gauging Application

The following example shows how the milliamp output of the sensor at full tank can be calculated. The "Reserve" represents the distance from the lowest point on the bottom of the tank to the installed sensor. "Full" is the level of contents at which the tank is filled to capacity. The liquid contents of the tank is milk @ 1.032 sp.gr. The sensor installed is a nominal 15 psig range model.

**C** = 1.032 (specific gravity)

**B** = 400 in. (full level)

**A** = 28 in. (reserve)

$$\frac{(400 - 28) \times 1.032}{27.6807} = 13.87 \text{ psig}$$

$$\frac{(16 \times 13.87) + 4}{15 \text{ psig}} = 18.79 \text{ mA}$$

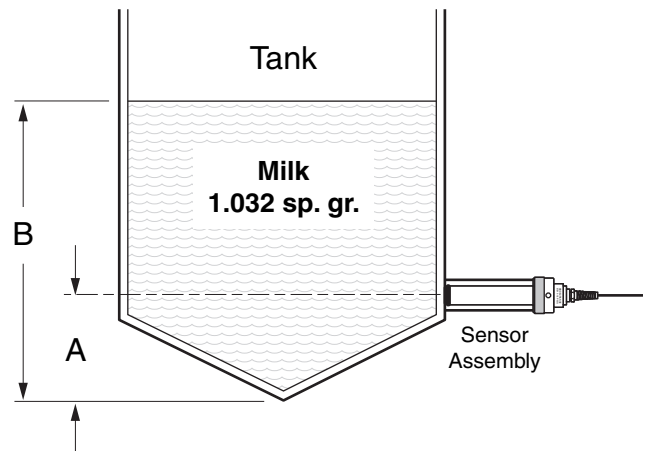

## Service Parts & Replacement

**O-ring seals:** The outer O-ring at the head of the sensing element forms the critical seal at the wetted process connection (generally within the tank mounting shell). This seal should be replaced if there are any signs of physical damage such as a cut to the O-ring.

**Signal wiring connectors:** The transmitter provides an M12 threaded outlet on the exterior of the housing that accepts an M12 (metric thread) connector.

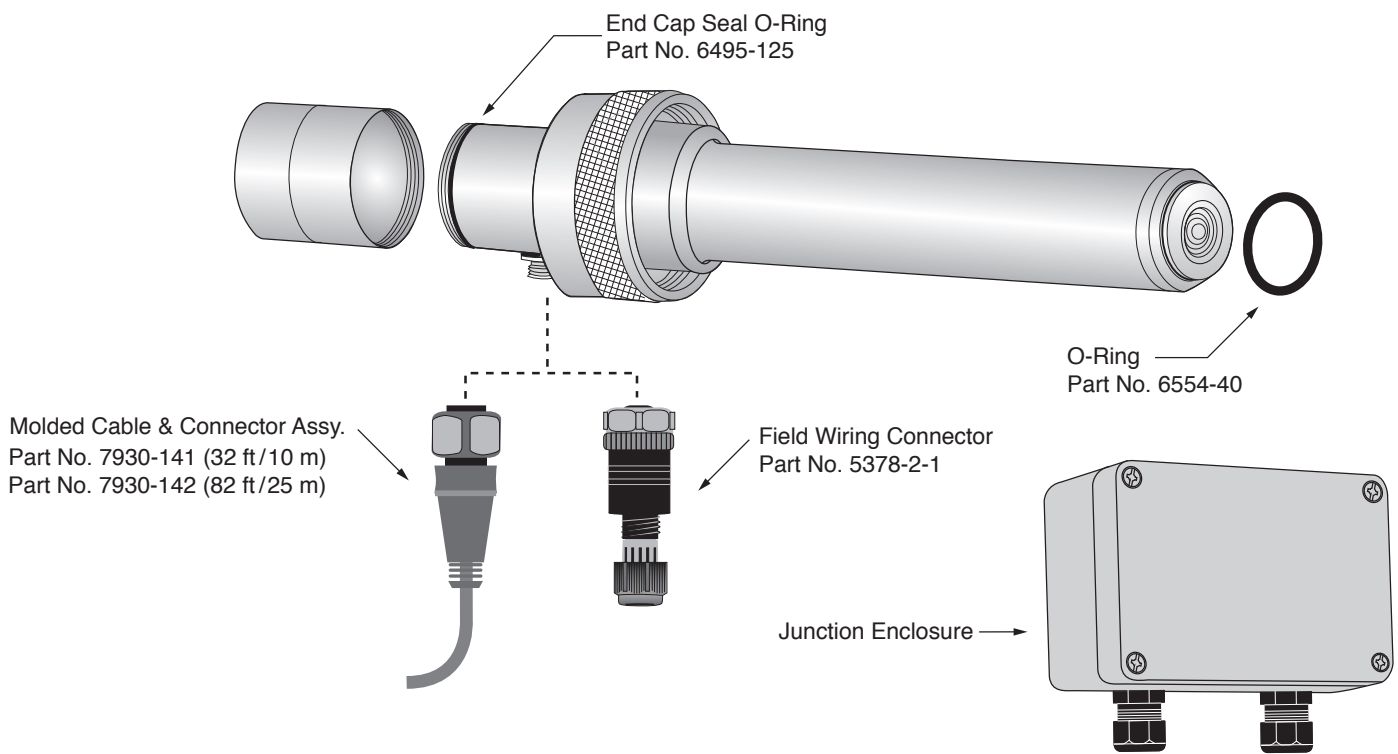

**ES2 Slimline Transmitter**

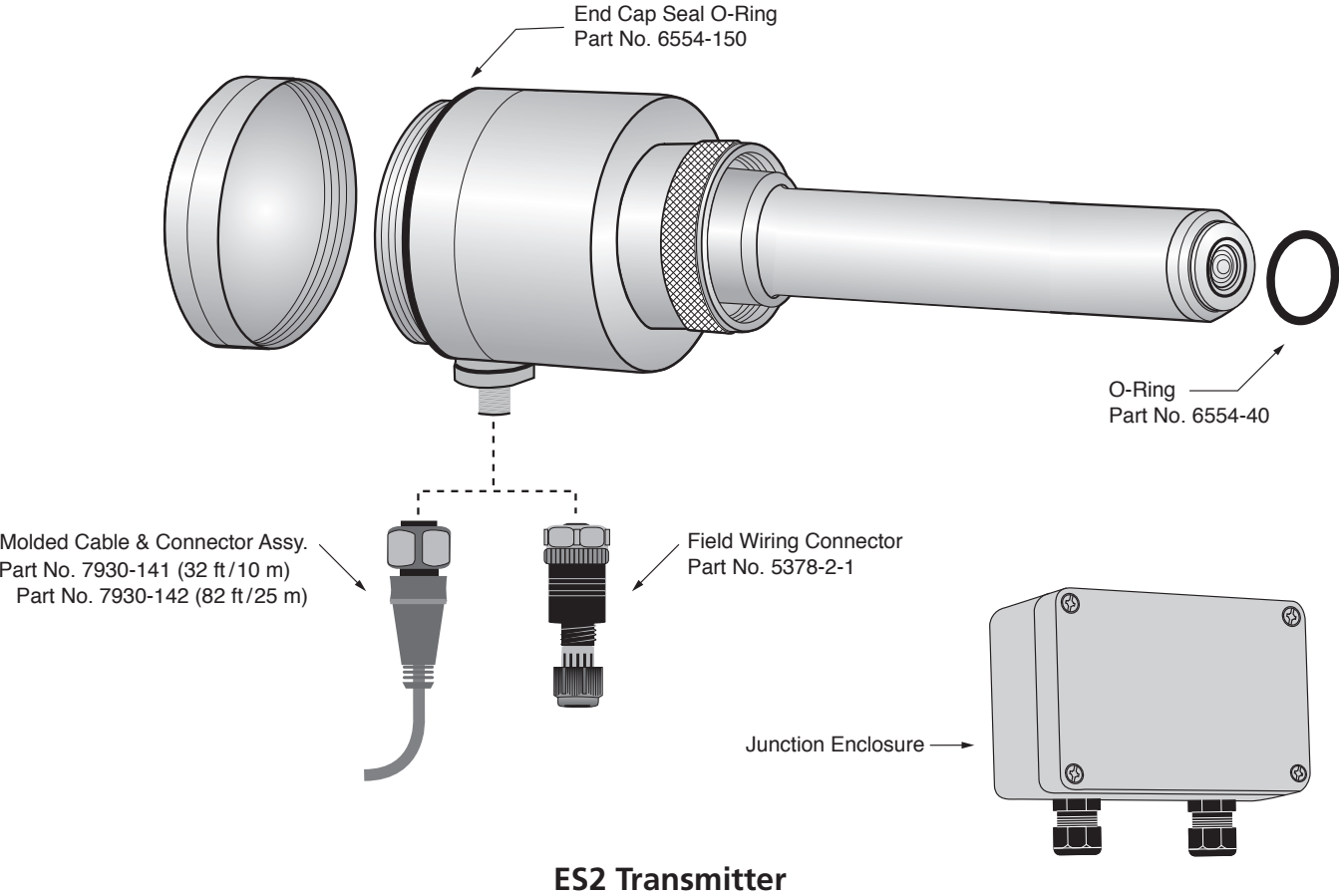



3201 South State St, Ann Arbor, Michigan 48108-1625 U.S.A.  
PO Box 1228, Ann Arbor, Michigan 48106-1228 U.S.A.  
Phone: (734) 662-5691 ■ FAX: (734) 662-6652  
[www.king-gage.com](http://www.king-gage.com)