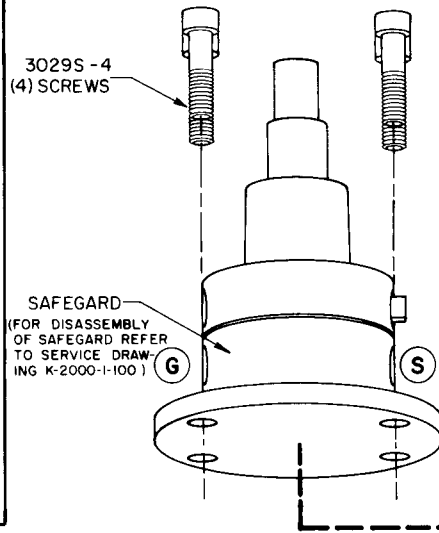

FIGURE A



SERVICING CONTROL SECTION

SERVICE KIT #7334-9 IS REQUIRED. REPLACE ALL APPLICABLE PARTS WITH REPLACEMENTS (KIT CONTAINS THOSE PARTS MARKED WITH ●). ALL OTHER PARTS MUST BE ORDERED SEPARATELY WHEN REPLACEMENT IS REQUIRED. SERVICE PRECAUTIONS -- CLEAN PORTS, VALVE SEAT AND AIR PASSAGES USING SOLVENT OR DETERGENT AND WATER. DRY WITH CLEAN COMPRESSED AIR.

OPTIONAL (NOT RECOMMENDED AS PART OF NORMAL SERVICE) -- USING A WRENCH, UNTHREAD CONNECTOR FROM BODY SECTION #2. REMOVE O-RING FROM CONNECTOR.

- ⑥ REMOVE BACK PRESSURE DIAPHRAGM ASSEMBLY (#4508-7) AND SPRING. REMOVE 2 SMALL O-RINGS IN BOLT CIRCLE OF BODY SECTION #2.
- ⑤ SEPARATE BODY SECTION #1 FROM BODY SECTION #2 (AS IN STEP 2).
- ④ REMOVE DIFFERENTIAL DIAPHRAGM ASSEMBLY (#4508-6) AND SPRING FROM BODY SECTION #1. REMOVE SMALL O-RING FROM BOLT CIRCLE. GENTLY GRIP AND UNSEAT ORIFICE ASSEMBLY BY ROTATING AND PULLING (SMALL PLIERS MAY BE REQUIRED, BUT USE ONLY LIGHT TO MODERATE PRESSURE SO AS TO PROTECT DELICATE JEWEL WITHIN ORIFICE).
- ③ REMOVE INTEGRAL VALVE FROM INLET DOME USING THE TOOL SUPPLIED IN REPLACEMENT VALVE KIT (#3257-1) CONTAINED IN SERVICE KIT #7334-9.
- ② SEPARATE BODY SECTION #1 FROM INLET DOME - GENTLY TAP THE SEAM WITH A Mallet and WEDGE UNTIL SEPARATION OCCURS. WHEN SEPARATED, SLIDE INLET DOME OFF THE "GUIDE RODS" (CAUTION: DO NOT LOSE OR DAMAGE THE FLOW CONTROL ORIFICE LOCATED IN BOLT CIRCLE OF BODY SECTION #1).
- ① REMOVE 2 OPPOSING SCREWS FROM THE 8 COUNTER-SUNK SOCKET-HEAD CAP

UNIT IS EQUIPPED WITH EITHER THE SAFEGARD OR OUTLET CONNECTION PLATE.

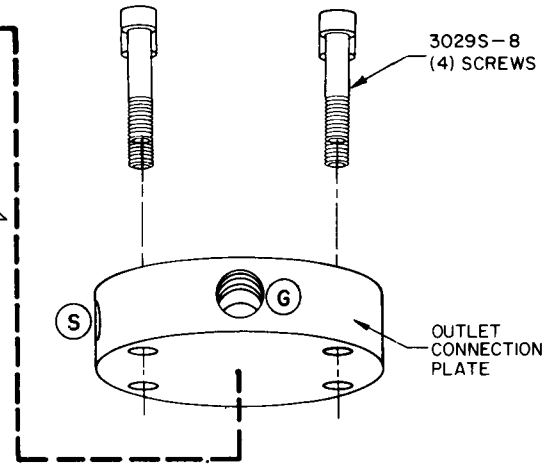
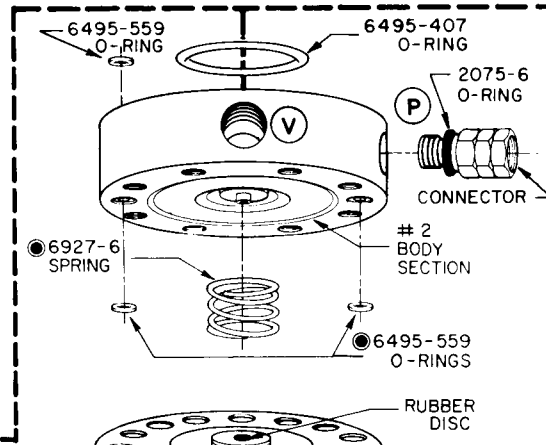

SUBASSEMBLY (IF CONNECTOR WAS REMOVED) LUBRICATE O-RING (#2075-6) AND INSTALL ONTO STEM OF CONNECTOR. THREAD CONNECTOR INTO BODY SECTION #2 UNTIL SNUG AGAINST SURFACE.

ASSEMBLY

PLACE UNIT SO BODY SECTION #2 IS FACING UP. ALIGNING MARK (REFER TO "PRELIMINARY SERVICE INSTRUCTIONS") SHOULD BE ALIGNED TO REAR OF BODY SECTION. "GUIDE RODS" SHOULD BE THREADED INTO OPPOSING HOLES IN BOLT CIRCLE, SEE FIGURE A.

- ① PLACE 2 SMALL O-RINGS (#6495-559) INTO RECESSED POCKETS IN BOLT CIRCLE OF BODY SECTION #2. TO ENSURE THAT O-RINGS STAY IN PLACE, DO NOT TIP UNIT UNTIL FINAL SCREWS ARE TIGHTENED.
- ② INSERT BACK PRESSURE SPRING (#6927-6), THE LIGHTER OF THE SPRINGS, SO IT SEATS OVER THE CENTER PROTRUSION OF BODY #2.
- ③ POSITION DIAPHRAGM ASSEMBLY (#4508-7), WITH RUBBER DISC IN CENTER FACING DOWN, OVER SPRING. CHECK ASSEMBLY BY DEPRESSING CENTER OF DIAPHRAGM ASSEMBLY. DIAPHRAGM SHOULD SPRING BACK UP -- IF NOT, REPLACE SPRING (#6927-6).
- ④ PLACE BODY SECTION #1 WITH DEEP RECESSED POCKET FACING UP. INSPECT ORIFICE ASSEMBLY (#4527-2) TO BE SURE O-RINGS ARE FREE OF NICKS OR CUTS. CAREFULLY LUBRICATE O-RINGS WITH SILICONE-BASED LUBRICANT - DO NOT PLUG ORIFICES.
- ⑤ **SUBASSEMBLY:** INSTALL ORIFICE ASSEMBLY INTO DEEPER OF THE TWO RECESSED POCKETS IN BOLT CIRCLE OF BODY SECTION #1. LARGER DIAMETER END OF ORIFICE ASSEMBLY SEATS IN POCKET. INSTALL SMALL O-RING (#6495-559) INTO OPPOSITE POCKET.
- ⑥ POSITION BODY SECTION #1 OVER DIAPHRAGM ASSEMBLY INSTALLED IN BODY SECTION #2. ORIFICE ASSEMBLY SHOULD BE FACING UP AND ALIGNING MARK CENTERED IN REAR.
- ⑦ POSITION DIFFERENTIAL SPRING (#6927-7), THE HEAVIER OF THE SPRINGS, IN THE DEEP CENTER POCKET OF BODY SECTION #1. POSITION DIAPHRAGM ASSEMBLY (#4508-6) OVER SPRING - FLAT HEAD OF RIVET FACING UP.

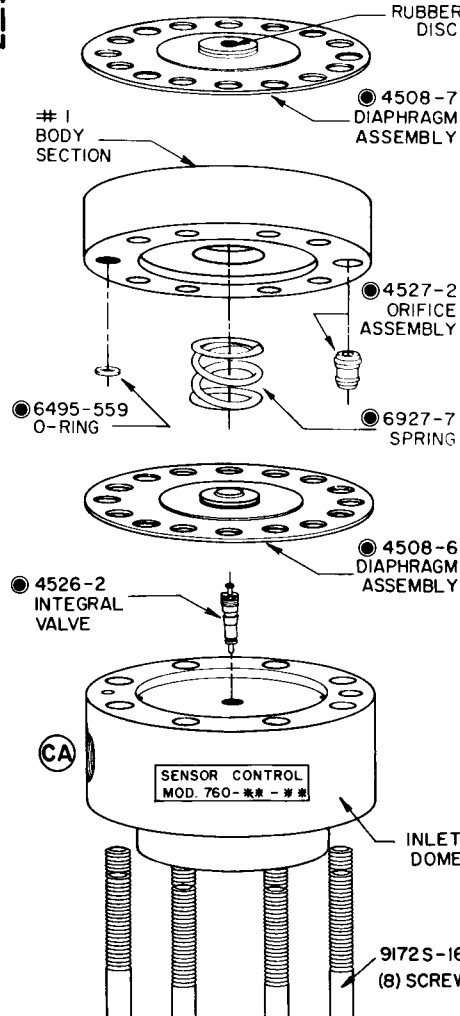

SCREWS (#9172S-16) ON THE INLET DOME. REPLACE WITH "GUIDE RODS" (FIGURE A) SUPPLIED IN SERVICE KIT #7334-9 AND TIGHTEN FINGER-TIGHT. REMOVE 6 REMAINING SCREWS.

IF MOUNTING BRACKET IS ATTACHED TO UNIT, REMOVE BRACKET. IF FILTER IS MOUNTED TO UNIT, REMOVE 4 SOCKET-HEAD CAP SCREWS AND DETACH FILTER. PLACE UNIT WITH INLET DOME FACING UP.

DISASSEMBLY

REPLACEMENT

1. MAKE SURE THERE IS NO DIRT WHERE FILTER PLUGS INTO INLET DOME.
2. TAKE NEW O-RINGS FROM SERVICE KIT (#7333-10) AND LIGHTLY GREASE WITH SILICONE-BASED LUBRICANT.
3. SLIP SMALL O-RING (#6495-5) OVER PROTRUDING TIP OF FILTER AND INSERT LARGE O-RING (#6495-226) INTO GROOVED RING.
4. GENTLY INSERT FILTER BY TWISTING UPWARDS BEING SURE LARGE O-RING REMAINS IN GROOVE.
5. ALIGN SCREW HOLES (WITH LABEL IN FRONT), INSERT AND TIGHTEN SOCKET-HEAD CAP SCREWS (#3028S-5) WITH MEDIUM TORQUE.

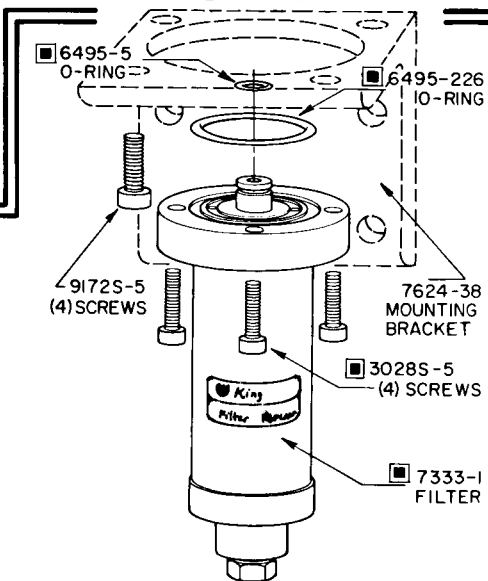

8. INSTALL INTEGRAL VALVE INTO INLET DOME. VALVE TOOL IS PROVIDED IN REPLACEMENT VALVE KIT. DO NOT OVERTIGHTEN VALVE OR DISTORTION WILL OCCUR.
9. SLIDE INLET DOME, WITH VALVE FACING DOWN, OVER "GUIDE RODS" AND ON TOP OF DIAPHRAGM ASSEMBLY. (LOCATING MARK SHOULD BE ALIGNED WITH OTHER MARKS.)
10. INSERT 6 SOCKET-HEAD SCREWS (#9172S-16) INTO BOLT CIRCLE, USING A SEQUENCE OF EVERY OTHER SCREW, PROCEED AROUND CIRCLE AND FINGER-TIGHTEN SCREWS. NOTE -- MAKE SURE ALIGNING MARKS ARE ALL CENTERED.
11. REMOVE "GUIDE RODS" AND INSERT 2 REMAINING SCREWS, USING A SEQUENCE OF EVERY OTHER SCREW, PROCEED AROUND BOLT CIRCLE AND TIGHTEN USING MODERATE TORQUE.

SERVICING FILTER SECTION

REQUIRES FILTER REPLACEMENT KIT #7333-10. REPLACE ALL APPLICABLE PARTS WITH REPLACEMENTS FROM KIT (INDICATED BY ■).

UNDER NORMAL CONDITIONS REPLACEMENT IS RECOMMENDED EVERY 12 MONTHS.

REMOVAL

REMOVE 4 SOCKET-HEAD CAP SCREWS (#3028S-5) AND REMOVE FILTER BY TWISTING OUTWARD.

PRELIMINARY SERVICE INSTRUCTIONS

IT IS RECOMMENDED THAT A CLEAN AND DRY WORK STATION BE AVAILABLE FOR SERVICING THE UNIT (FILTER MAY BE REPLACED IN MOUNTING LOCATION). SOCKET-HEAD SCREW WRENCHES (ALLEN TYPE) OF THE FOLLOWING SIZES ARE REQUIRED -- 3/16", 5/32" AND 9/64". A Mallet and small wedge may be necessary to separate some body sections.

DO NOT USE PROBES OR WIRE BRUSHES TO CLEAN INTERNAL SURFACES. EXERCISE CAUTION WHEN USING PLIERS TO REMOVE FLOW CONTROL ORIFICES. ORIFICE CONTAINS DELICATE JEWEL WHICH MAY BE DAMAGED BY EXCESSIVE FORCE.

CONTROL UNIT CONTAINS MANY SMALL PARTS, OF WHICH PROPER INSTALLATION IS NECESSARY FOR ACCURATE OPERATION. "ALIGNING MARKS" ARE PROVIDED (SEE FIGURE AT RIGHT) FOR CORRECT ORIENTATION OF BODY SECTIONS DURING ASSEMBLY. FOLLOW INSTRUCTIONS CAREFULLY.

BEFORE ANY SERVICE IS STARTED

1. TANK LIQUID MAY BE AT ANY LEVEL IN TANK WHEN SERVICING CONTROL UNIT.
2. TURN OFF AIR SUPPLY TO CONTROL UNIT.
3. FOR EASE OF RE-INSTALLATION LABEL INDIVIDUAL TUBES WITH CORRESPONDING PORT CONNECTION LETTER (DISCONNECT ALL TUBES AT CONTROL UNIT).
4. SEPARATE CONTROL UNIT FROM MOUNTING BRACKET BY REMOVING 4 SOCKET-HEAD CAP SCREWS LOCATED ON THE UNDERSIDE OF THE MOUNTING BRACKET. (THIS STEP IS NOT REQUIRED FOR FILTER REPLACEMENT.)

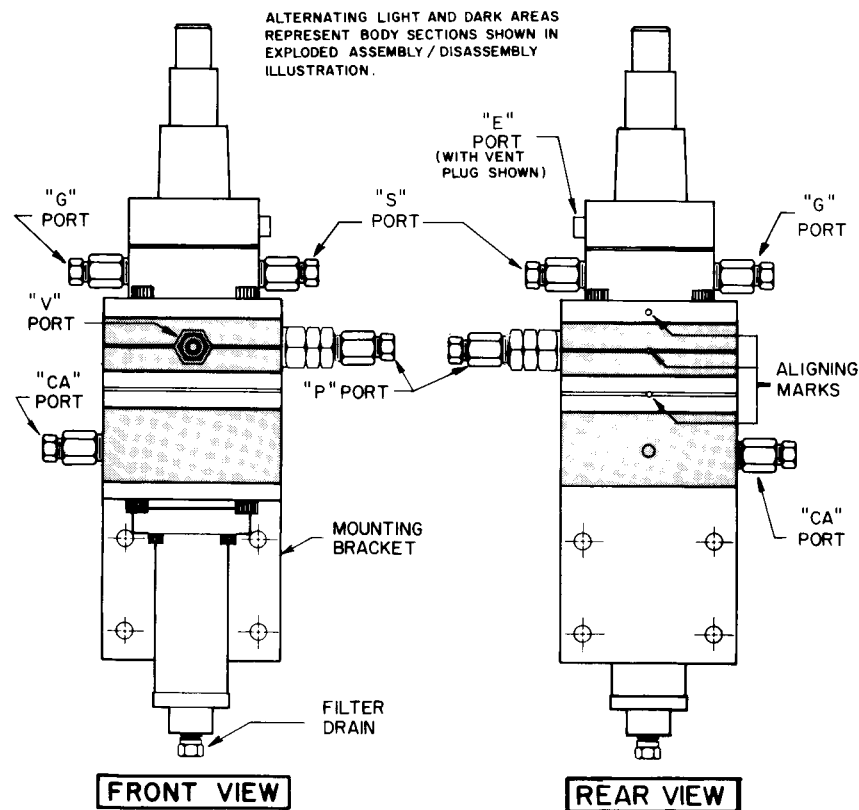

SERVICE DRAWING — ASSEMBLY AND DISASSEMBLY INSTRUCTIONS
MODEL 760
SAFEGARD SENSOR CONTROL OR SENSOR CONTROL (WITHOUT SAFEGARD).