

FILTER REPLACEMENT KIT 7333-10

KIT CONTAINS REPLACEMENT FILTER ASSEMBLY, O-RINGS AND SCREWS. REPLACE ALL APPLICABLE PARTS (INDICATED BY □) WITH ITEMS IN SERVICE KIT.

NOTE: UNDER NORMAL CONDITIONS, REPLACEMENT IS RECOMMENDED AT 12 MONTH INTERVALS. SOME CONDITIONS MAY WARRANT MORE FREQUENT REPLACEMENT.

FILTER REMOVAL

UNTHREAD 4 SOCKET-HEAD SCREWS (3028S-5) AND PULL OUTWARD ON FILTER TO REMOVE.

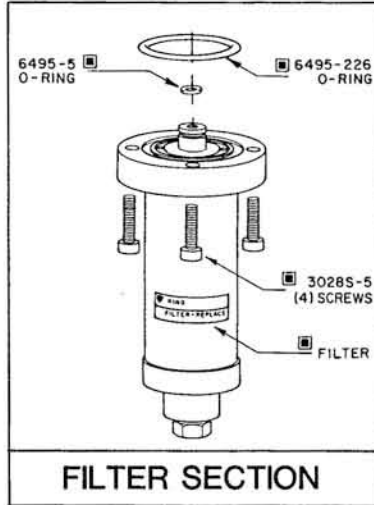

FILTER INSTALLATION

1. WIPE ANY DIRT OR RESIDUE FROM SURFACE WHERE FILTER MOUNTS TO THE CONTROL.
2. INSTALL O-RINGS INCLUDED IN KIT ONTO THE FILTER ASSEMBLY. SMALL O-RING (6495-5) FITS GROOVE ON THE PROTRUDING NIPPLE; LARGER O-RING (6495-226) SHOULD BE PLACED INTO THE GROOVE ON FLANGED END.
3. WITH O-RINGS PROPERLY SITUATED, INSTALL FILTER ASSEMBLY INTO BOTTOM OF THE INLET DOME OF CONTROL. SITUATE FILTER SO THAT LABEL IS CLEARLY VISIBLE.
4. INSTALL THE 4 SOCKET-HEAD SCREWS AND TIGHTEN SECURELY. (BE CERTAIN TO REMOVE PLASTIC CAP FROM FILTER DRAIN).

INTRODUCTION

THE LIQUISEAL CONTROL IS A PNEUMATIC PRESSURE TRANSMITTER AND SIGNAL CONDITIONER. CLEAN, DRY AND OIL-FREE COMPRESSED AIR (OR INERT GAS) IS REQUIRED FOR PROPER OPERATION. THE INTERNAL PORTING AND PRECISION FLOW ORIFICES MAY BECOME OBSTRUCTED IF LIQUID CONTAMINANTS (WATER, OIL, ETC.) ARE INTRODUCED INTO THE CONTROL.

WHEN SERVICING THE CONTROL, MAKE CERTAIN THAT ALL INTERNAL PARTS AND SURFACES ARE CLEAN AND DRY. INTERNAL PORTING SHOULD BE BLOWN CLEAR USING CLEAN COMPRESSED AIR. FLOW ORIFICES SHOULD BE REPLACED IF CONTAMINATED. (ATTEMPTING TO CLEAR FLOW ORIFICES WITH WIRE OR OTHER PROBE WILL ONLY DAMAGE THE ORIFICE.)

THE LIQUISEAL CONTROL IS ILLUSTRATED BELOW. PROPER ORIENTATION OF THE VARIOUS COMPONENT PARTS IS CRITICAL. REFER TO THE "ALIGNING MARKS" FOUND ON THE OUTSIDE OF THE ASSEMBLY. THESE SMALL DIMPLES (INDENTATIONS) ARE USED TO POSITION INDIVIDUAL BODY SECTIONS DURING RE-ASSEMBLY. IF CORRECTLY ASSEMBLED, THESE MARKS SHOULD ALL LINE UP (SEE REAR VIEW).

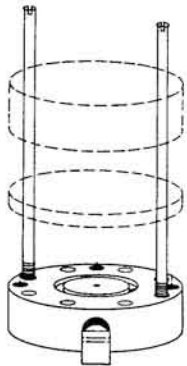

GUIDE RODS

"GUIDE RODS" ARE FURNISHED WITH SOME OF THE SERVICE KITS. THESE ALLOW THE VARIOUS BODY SECTIONS TO BE "STACKED UP" PRIOR TO INSTALLING ASSEMBLY SCREWS.

REQUIRED TOOLS

ALLEN WRENCHES
— 3/16", 5/32", 9/64"

LIQUISEAL PURGE CONTROL MODEL NO. DESIGNATION

737-***1*-***

CAPSULE KIT 535 IS USED ONLY ON CONTROLS HAVING SERIES NO. 2180. ONLY SERIES 2180 CONTROLS INCORPORATE THE (R) PORT AS SHOWN BELOW.

ORIFICE CHECK VALVE	
5	S.S. 5CFH (7366-4)
6	BRASS 5CFH (7366-3)
7	S.S. 1CFH (7366-2)
8	BRASS 1CFH (7366-1)

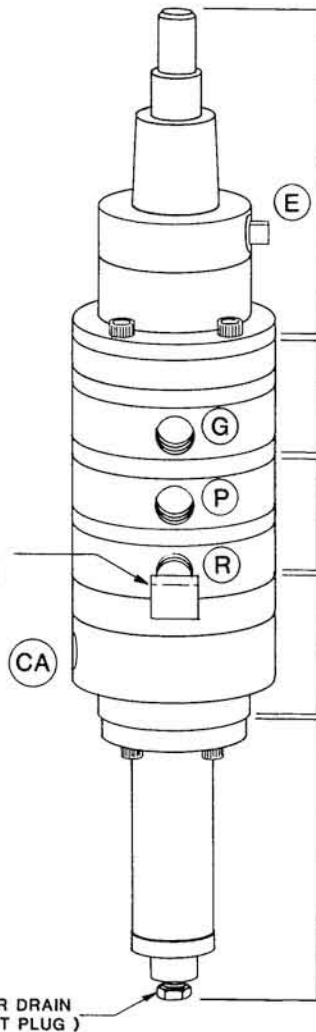

FRONT VIEW

SAFEGARD SECTION
(REFER TO SEPARATE SERVICE DRAWING)

DYNAMIC CAPSULE SECTION
CAPSULE KIT 534/535

SENSING SECTION
SERVICE KIT 7334-21

CONTROL SECTION
SERVICE KIT 7334-9

FILTER SECTION
REPLACEMENT KIT 7333-10

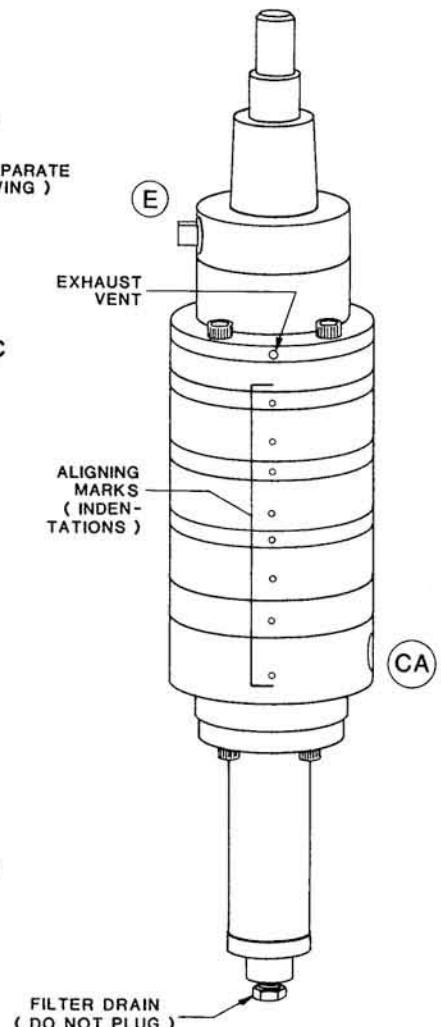

REAR VIEW

ALL-25-85 RELEASED
 KING ENGINEERING CORPORATION
 BOX 1228, ANN ARBOR, MI 48106 U.S.A.
 313/662-6691 TELE: 23-4040
 SERVICE DRAWING
 ASSEMBLY AND DISASSEMBLY INSTRUCTIONS
 MODEL 737
 DYNAGARD LIQUISEAL PURGE CONTROL
 K-2000-2-737
 PAGE 1 OF 3
 BEV

DISASSEMBLY SENSING SECTION

1. REMOVE THE 8 SOCKET-HEAD SCREWS (9172S-10) FROM TOP OF OUTLET DOME.
2. SEPARATE THE VARIOUS BODY SECTIONS (OUTLET DOME, DIAPHRAGM RING) AND GASKET FROM TOP OF BODY #2 AS SHOWN TO EXPOSE INTERNAL DIAPHRAGM. USE CARE WHEN HANDLING DIAPHRAGM IF IT IS TO BE RE-INSTALLED LATER.
3. OPTIONAL — UNTHREAD ORIFICE CHECK VALVE FROM INTERIOR OF OUTLET DOME IF IT REQUIRES CLEANING OR REPLACEMENT.

SERVICE KIT 7334-21

ITEMS INDICATED BY Δ ON THIS SHEET ARE INCLUDED IN THE SERVICE KIT. REPLACE ALL APPLICABLE PARTS. OTHER PARTS NOT INCLUDED IN KIT WILL HAVE TO BE ORDERED SEPARATELY IF REPLACEMENT IS REQUIRED. REFER TO SHEET 1 FOR PROPER ORIFICE CHECK VALVE AND REPLACEMENT DIAPHRAGM SELECTION.

PRIOR TO INSTALLING REPLACEMENT PARTS, MAKE CERTAIN THAT ALL INTERNAL SURFACES ARE CLEAN AND DRY.

IMPORTANT !

IF CONTROL HAS EVIDENCE OF LIQUID CONTAMINATION, THE ENTIRE UNIT MUST BE DISASSEMBLED AND CLEANED BEFORE INSTALLING ANY REPLACEMENT PARTS.

IF SERVICE KIT OR REPLACEMENT PARTS ARE NOT USED, MAKE CERTAIN THAT ALL PARTS REMOVED DURING DISASSEMBLY ARE PRESENT. CHECK THAT YOU HAVE CORRECT NUMBER OF SMALL O-RINGS. CONTROL WILL NOT FUNCTION PROPERLY IF ANY PARTS ARE MISSING.

SERVICE KIT 7334-9

ITEMS INDICATED BY \odot ON THIS SHEET ARE INCLUDED IN THE SERVICE KIT. REPLACE ALL APPLICABLE PARTS. OTHER PARTS NOT INCLUDED IN KIT WILL HAVE TO BE ORDERED SEPARATELY IF REPLACEMENT IS REQUIRED.

PRIOR TO INSTALLING REPLACEMENT PARTS, MAKE CERTAIN THAT ALL INTERNAL SURFACES ARE CLEAN AND DRY.

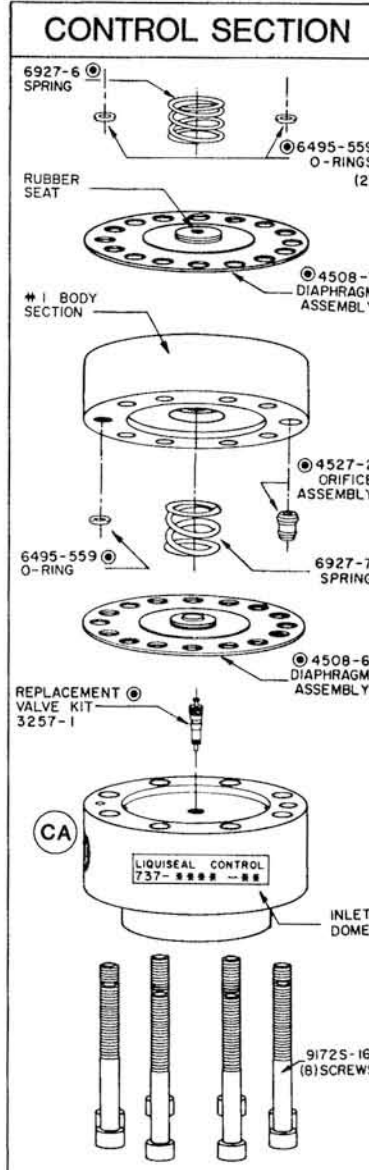
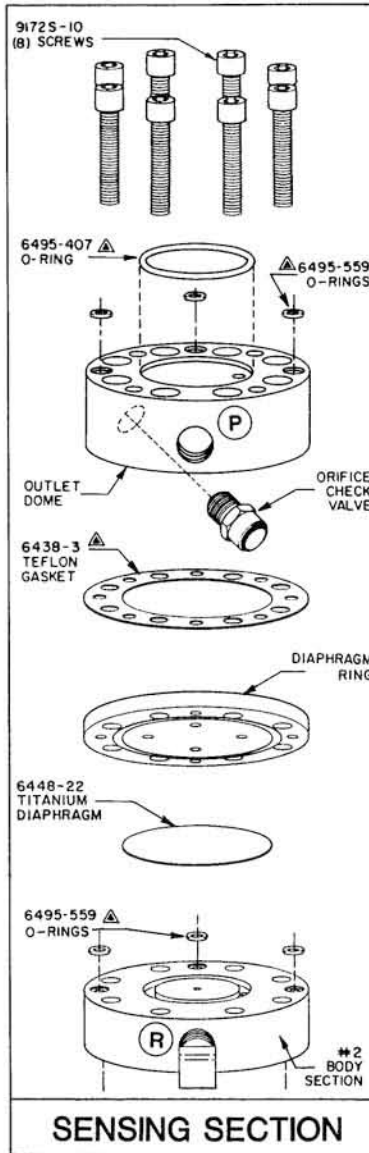

9. REMOVE THE "GUIDE RODS" AND REPLACE WITH THE 2 REMAINING SOCKET-HEAD SCREWS. USING A SEQUENCE OF EVERY OTHER SCREW, PROCEED AROUND BOLT CIRCLE AND TIGHTEN WITH A MINIMUM 10 FT/LBS TORQUE.
8. INSTALL 6 OF THE SOCKET-HEAD SCREWS (9172S-10) AND THREAD UNTIL FINGER-TIGHT. CHECK THE INDENTATIONS ON OUTSIDE EDGES OF BODY SECTIONS TO ENSURE BODY SECTIONS ARE PROPERLY LINED UP.
7. PLACE LARGE O-RING (6495-407) AND SMALL O-RINGS (6495-559) IN POCKETS ON TOP OF OUTLET DOME. CURRENT LIQUEAL CONTROLS HAVE 3 O-RING POCKETS; PREVIOUS MODELS EMPLOY ONLY 2 O-RING POCKETS.
6. INSTALL OUTLET DOME, MAKING CERTAIN SMALL INDENTATION IS ALIGNED WITH SIMILAR INDENTATION ON EDGE OF DIAPHRAGM RING. ("P" PORT SHOULD ALSO BE ALIGNED WITH "R" VENTED PLUG FOUND ON BODY #2).
5. OPTIONAL — IF ORIFICE CHECK VALVE WAS REMOVED, THREAD REPLACEMENT INTO OUTLET DOME. DO NOT OVERTIGHTEN!
4. PLACE DIAPHRAGM RING OVER DIAPHRAGM (MAKING CERTAIN DIAPHRAGM DOESN'T SHIFT POSITION). SMALL INDENTATION ON SIDE OF RING SHOULD BE ALIGNED WITH SIMILAR INDENTATION FOUND ON BODY #2. POSITION TEFLON GASKET (6438-3) OVER "GUIDE RODS" AND INSTALL ON TOP OF DIAPHRAGM RING.
3. PLACE DIAPHRAGM IN CENTER OF BODY #2. DIAPHRAGM MUST BE HANDLED WITH CARE TO AVOID WRINKLING.
2. PLACE SMALL O-RINGS (6495-559) INTO POCKETS IN BOLT CIRCLE OF BODY #2. CURRENT LIQUEAL CONTROLS HAVE 3 O-RING POCKETS; PREVIOUS MODELS EMPLOY ONLY 2 O-RING POCKETS. KEEP UNIT UPRIGHT TO ENSURE O-RINGS REMAIN IN POSITION.
1. INSTALL THE TWO "GUIDE RODS" INTO OPPOSING HOLES IN THE BOLT CIRCLE OF BODY #2.

ASSEMBLY SENSING SECTION

ASSEMBLY CONTROL SECTION

1. INSTALL THE TWO "GUIDE RODS" INTO OPPOSING HOLES IN THE BOLT CIRCLE OF BODY #2.
 2. PLACE 2 SMALL O-RINGS (6495-559) INTO POCKETS IN THE BOLT CIRCLE OF BODY #2. KEEP UNIT UPRIGHT TO ENSURE O-RINGS REMAIN IN POSITION.
 3. INSERT BACK PRESSURE SPRING (6927-6; THE LIGHTER OF THE TWO SPRINGS) INTO CENTER POCKET OF BODY #2.
 4. INSTALL DIAPHRAGM ASSEMBLY (4508-7) OVER "GUIDE RODS." NOTE THAT THIS DIAPHRAGM HAS A SMALL RUBBER SEAT (SEE ILLUSTRATION) THAT SEALS AGAINST THE VENT NOZZLE ON BODY #2. CHECK SPRING ACTION BY DEPRESSING CENTER OF DIAPHRAGM ASSEMBLY TO ENSURE PARTS ARE PROPERLY SITUATED.
 5. INSTALL BODY #1 OVER "GUIDE RODS" SO THAT THE INDENTATION IS ALIGNED WITH ONE ON BODY #2.
 6. BODY #1 HAS 2 POCKETS IN THE BOLT CIRCLE. INSERT LARGER DIAMETER END OF THE ORIFICE ASSEMBLY (4527-2) INTO THE DEEPER POCKET. IT SHOULD FIT SNUGLY. PLACE SMALL O-RING (6495-559) INTO THE OTHER POCKET IN BOLT CIRCLE OF BODY #1.
- NOTE: THE ORIFICE ASSEMBLY SHOULD BE HANDLED DELICATELY BECAUSE IT CONTAINS A JEWELLED FLOW ORIFICE THAT IS EASILY DAMAGED.
7. INSERT HEAVIER SPRING (6927-7) INTO CENTER POCKET OF BODY #1. PLACE DIAPHRAGM ASSEMBLY (4508-6) OVER "GUIDE RODS" WITH THE FLAT BRASS BUTTON SIDE UP. DO NOT INSTALL THIS SIDE AGAINST SPRING.
 8. SUBASSEMBLY — INSTALL REPLACEMENT VALVE KIT INTO THREADED POCKET IN CENTER OF INLET DOME. USE INSTRUCTIONS PROVIDED IN KIT.
 9. INLET DOME HAS A MATING POCKET IN THE BOLT CIRCLE TO ACCEPT THE OTHER END OF THE ORIFICE ASSEMBLY. ORIENT THIS POCKET WITH THE ORIFICE AND SLIDE INLET DOME OVER "GUIDE RODS."
 10. INSTALL 6 OF THE SOCKET-HEAD SCREWS AND THREAD UNTIL FINGER-TIGHT. CHECK THE INDENTATIONS ON OUTSIDE EDGES OF BODY SECTIONS TO ENSURE BODY SECTIONS ARE PROPERLY LINED UP.
 11. REMOVE THE "GUIDE RODS" AND REPLACE WITH THE 2 REMAINING SOCKET-HEAD SCREWS. USING A SEQUENCE OF EVERY OTHER SCREW, PROCEED AROUND BOLT CIRCLE AND TIGHTEN USING MODERATE TORQUE.

DISASSEMBLY CONTROL SECTION

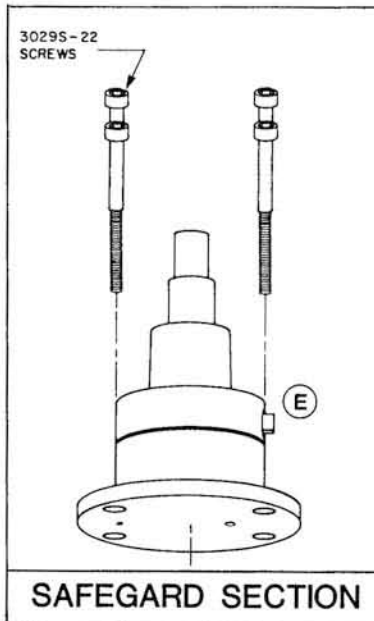

SAFEGARD

SAFEGARD (IF APPLICABLE) IS A SERVICEABLE ASSEMBLY. REFER TO SEPARATE SAFEGARD SERVICE DRAWING FOR COMPLETE DISASSEMBLY AND SERVICE PARTS.

DISASSEMBLY CAPSULE SECTION

1. REMOVE THE 4 SOCKET-HEAD SCREWS THAT FASTEN BOTH THE SAFEGARD AND CAPSULE TO THE TOP OF THE LIQUISEAL CONTROL.
2. DISCARD O-RINGS FROM TOP OF OUTLET DOME IF REPLACEMENT CAPSULE IS TO BE INSTALLED.

REPLACEMENT CAPSULE KIT

ITEMS INDICATED BY  ON THIS SHEET ARE INCLUDED IN THE REPLACEMENT CAPSULE KITS # 534 AND # 535.

IMPORTANT !

IF CONTROL HAS EVIDENCE OF LIQUID CONTAMINATION, THE ENTIRE UNIT MUST BE DISASSEMBLED AND CLEANED BEFORE INSTALLING ANY REPLACEMENT PARTS.

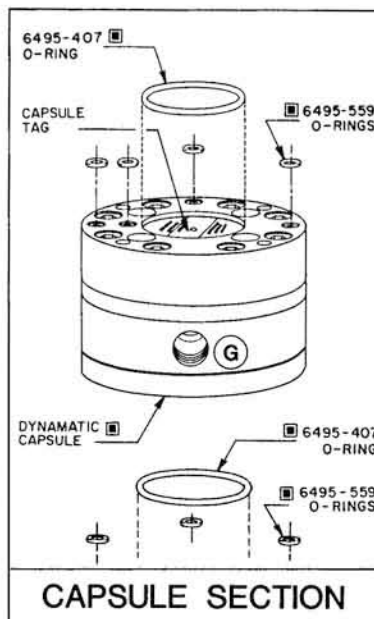

6. USING A SEQUENCE OF EVERY OTHER SCREW, TIGHTEN EVENLY WITH MEDIUM TORQUE.
5. INSERT 4 SOCKET-HEAD SCREWS (3029S-16) AND FINGER-TIGHTEN TO HOLD SAFEGARD (OR OUTLET PLATE) AND CAPSULE ASSEMBLY IN PLACE.
4. INSTALL SAFEGARD OR OUTLET CONNECTION PLATE OVER CAPSULE. (IF INSTALLING SAFEGARD, CHECK THAT SMALL INDENTATION ON OUTSIDE EDGE OF FLANGE IS ALIGNED WITH SIMILAR INDENTATIONS FOUND ON BODY OF CONTROL.)
3. PLACE LARGE O-RING (6495-407) IN CENTER POCKET AND SMALL O-RINGS (6495-559) INTO POCKETS IN THE BOLT CIRCLE ON TOP OF REPLACEMENT CAPSULE. (CAPSULE KIT # 535 USES 4 SMALL O-RINGS.) (CAPSULE KIT # 534 USES 3 SMALL O-RINGS.)
2. POSITION CAPSULE (WITH TAG SIDE UP) OVER OUTLET DOME. THE "G" PORT SHOULD BE ALIGNED DIRECTLY OVER "P" PORT OF CONTROL.
1. PLACE LARGE O-RING (6495-407) AND SMALL O-RINGS (6495-559) INTO POCKETS AT TOP OF OUTLET DOME. CURRENT LIQUISEAL CONTROLS HAVE 3 O-RING POCKETS; PREVIOUS MODELS EMPLOY ONLY 2 O-RING POCKETS.

ASSEMBLY CAPSULE SECTION

