

Service Parts & Dimensions 1010-10.40

Effective: February, 2011 (replaces May, 2009)

Model 5992 Tank Level Indicator w/ Hand Pump

Liquid Level Indicator Specifications

- **Operating Principle**
Well-type manometer acts as a frictionless hydrostatic force-balance. A liquid fill is raised in direct proportion to the magnitude of pressure applied. (Varies based on type of indicating liquid employed.)
- **Resolution**
Infinite based on type of indicating liquid employed.
- **Input Connection(s)**
1/4" NPT tapped connection for typical tube fittings. Accepts pneumatic air/gas pressure input; high and low pressure inputs.
- **Materials of Construction**
Formed channel indicator housing; brushed stainless steel (type 304). Heavy plate glass window; acrylic plastic window available as special order.
- **Wetted Parts**
316 stainless steel liquid well and tubing.
- **Indicating Tube**
High strength, fully annealed glass (Pyrex®)
- **KING-GAGE Indicator**
Single display tube. Available in wall mount housing only.
Scale Ranges: 20", 35", 43", 51", 66"

Dimensions by Indicator Range (inches)

Range	Dim. "A"	Dim. "B"
20	26-1/4	25-3/8
35	42-1/4	41-3/8
43	50-1/4	49-3/8
51	58-1/4	57-3/8
66	74-1/4	73-3/8

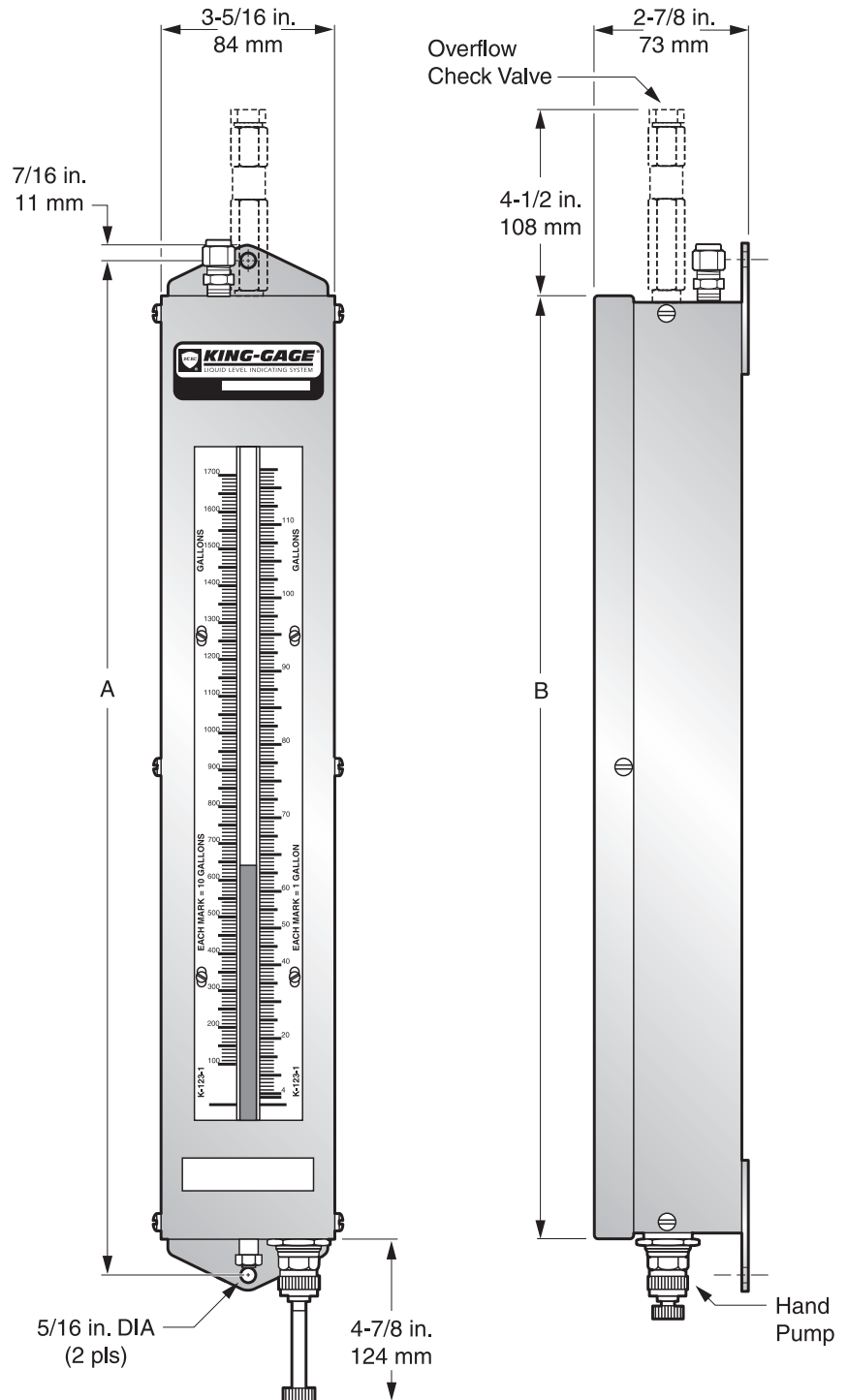

Model 5992 Service Parts:

Item	Description	Part No.	Qty.	Notes
1	Top Plate	5143F-2	1	1
	Top Plate	5143S-2	1	1
2	Bottom Plate	5142F-2	1	1
	Bottom Plate	5142S-2	1	1
3	Gage Repl. Well	7754-20, -35	1	2
	(includes: gauge well fab., drain plug, nylon washer, pressure tube, & well conn. nut)	7755-43, -51, -66	1	2
4	Drain Plug	7560	1	
	(included with item 3)			
	Washer, Nylon	6997	1	
	(included with item 3)			
5	Glass Tube Repl. Kit	5159-x	1	2
	(includes: glass tube, packing washers, o-rings, & well conn. nut)			
	Glass Tube Packing Seal Kit	5181-1	1	
	(includes: packing washers, o-rings, & well conn. nut)			
6	Front Cover Assembly	8815F-x	1	1,2
	Front Cover Assembly	8815S-x	1	1,2
7	Glass & Molding Assy.	8866-x	1	2
	(included with item 6)			
8	Hand Pump Repl. Kit	5154-1-43, -81	1	2
	(tube is trimmed for shorter ranges)			
9	Plunger Assy.	3811	1	
	(included with item 8)			
10	Replacement Scale			
	1-Unit Scale	7083-x	1	5
	2-Unit Scale	7084-x	1	5
11	Replacement Liquid			
	Red, No. 294	2992-x	1	3
	Purple, No. 175	9175-x	1	3
	Mercury	2604-3-1	1	4
12	Overflow Check Valve	8838	1	
13a	Swagelok Fitting	8437B-23	1	
13b	Repl. Top Fitting	5161-2	1	
	(includes: conn. tube, hex pipe bushings, pipe tee, pipe nipple, & tube fittings)			
14	Reflector	7761-x	1	2

Notes:

1. F=painted steel, S=stainless steel.
2. Dash number indicates range.
3. Dash number indicates bottle size (8 or 16 oz. bottles only).
4. Sold by weight (1 lb. bottles only).
5. When ordering a replacement scale, the following information must be supplied:
 - Tank Designation
 - Unit(s) of measurement
 - Scale serial number
 - Specific gravity, product density, etc.
6. Item 13b applies to older configurations that incorporated three (3) connection ports on the top plate.

© KING-GAGE and the KE emblem are registered trademarks of King Engineering Corporation, Ann Arbor, Michigan U.S.A.

All specifications are subject to change without notice.

© 2011 King Engineering Corporation. All rights reserved.

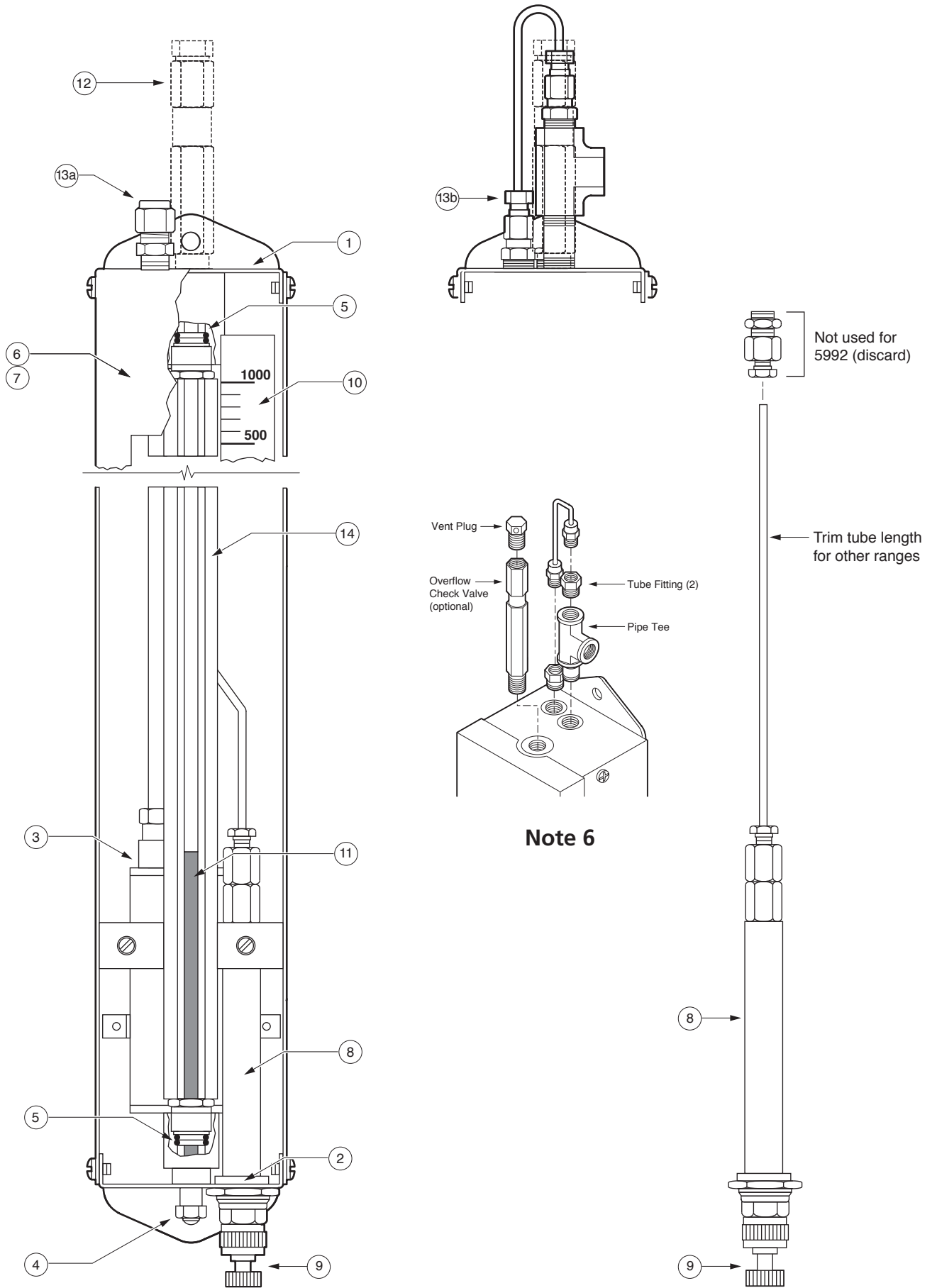

This page intentionally left blank