

Models 4650-1 (with Analog Output) • 4650-2 (with Relay Outputs)

Effective: July 2016

EX-1860-R

Installation and Operations Manual



The information contained in this manual was accurate at the time of release. Specifications are subject to change without notice.

ATC King Engineering Division. All rights reserved.

Limited Warranty

ATC King Engineering Division products are warranted to the first direct purchaser its products against defective material and workmanship for a period of one (1) year from the date of purchase. The Company will either; repair, replace or refund the purchase price, at its option, if the product proves to be defective provided the purchaser notified The Company of the alleged defect within a reasonable time of its discovery and returns the products to The Company for evaluation, free of any liens and encumbrances. The purchaser shall return the alleged defective products and address notification of alleged defects to either of the addresses shown below.

This warranty is expressly in lieu of all other warranties expressed or implied, including the warranties of merchantability and fitness for use and all other obligations or liabilities on the part of The Company, and The Company neither assumes nor authorizes any other person to assume for it, and other liability in connection with the sale hereunder. The Company disclaims any liability for product defects that are due to product misuse, improper product selection or misapplication.

The Company shall not be liable for customer's costs, lost profits, good will or other special or consequential damages. The Company's liability in all events is limited and shall not exceed, the value of merchandise involved.

Revisions:

- (A) February 2016 – Original Release
- (B) July 2016 – Revised with Model 4650-2 relays, Modbus notes

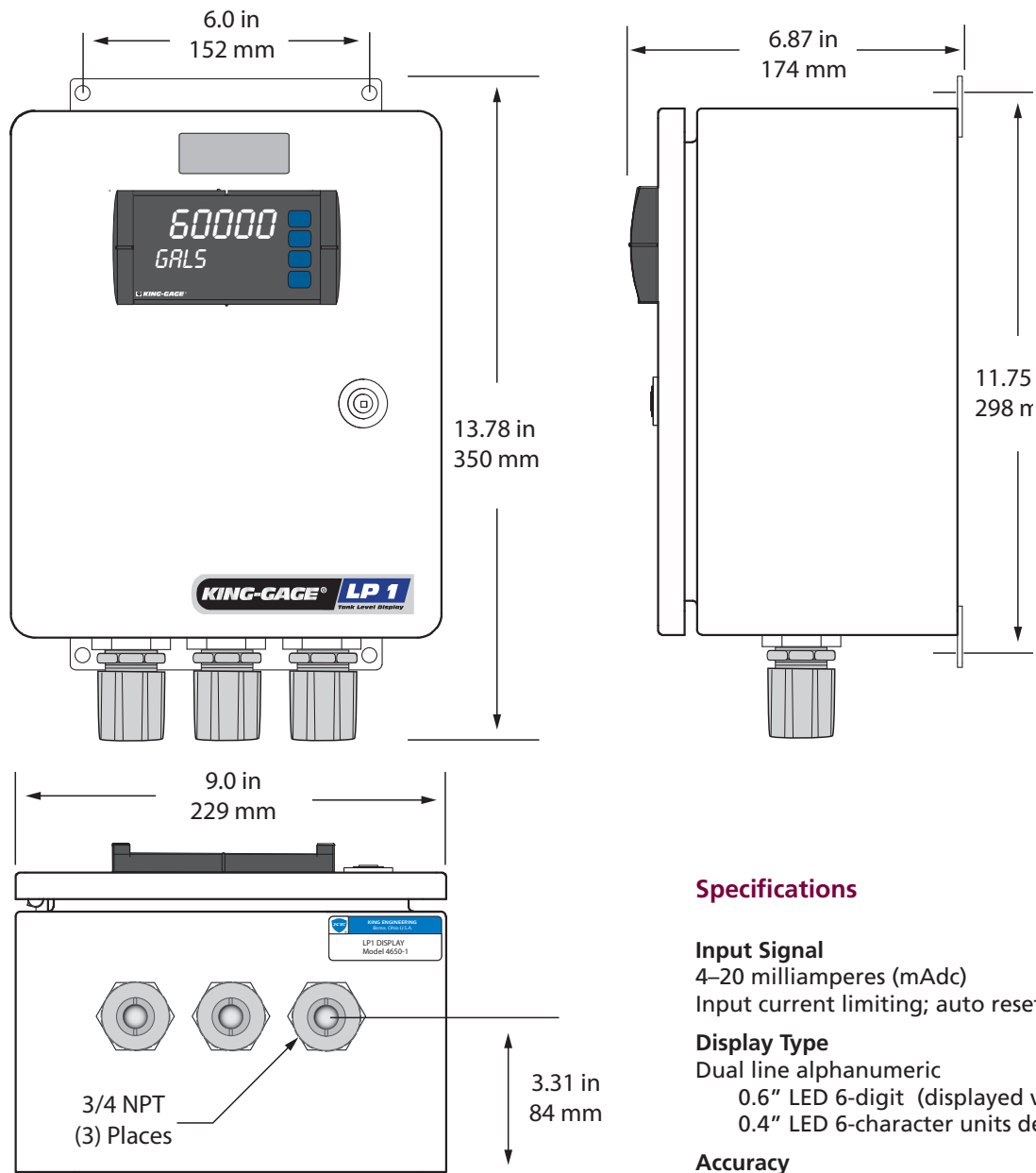

KING-GAGE LP1 Single Tank Display

The LP1 digital indicator provides continuous level measurement of liquid inventory in storage or processing tanks. A tank capacity profile is factory-programmed into the internal memory to convert the proportional input signal (4-20mA) into an accurate reading of volume, weight or depth of liquid in the tank.

The LP1 is supplied in stainless steel enclosure suitable for indoor or outdoor locations. The LP1 system requires an electrical supply (85-265 Vac) for operation. Nylon water-tight cable grip connectors are supplied for wiring entries into the enclosure.

Specifications

Input Signal

4–20 milliamperes (mAdc)

Input current limiting; auto reset internal fuse

Display Type

Dual line alphanumeric

0.6" LED 6-digit (displayed value)

0.4" LED 6-character units designator

Accuracy

±0.03% calibrated span

Resolution

24-bit A/D conversion, ±1 count

Temperature Range

-40° to 140°F/-40° to 60°C

(operating range)

Power Requirements

85-265 Vac 50/60 Hz

Voltage Output

24 Vdc (@ 200 mA)

Ratings

IP65

(equivalent to NEMA 4X)



LP1 front panel (dual line LED alphanumeric display)

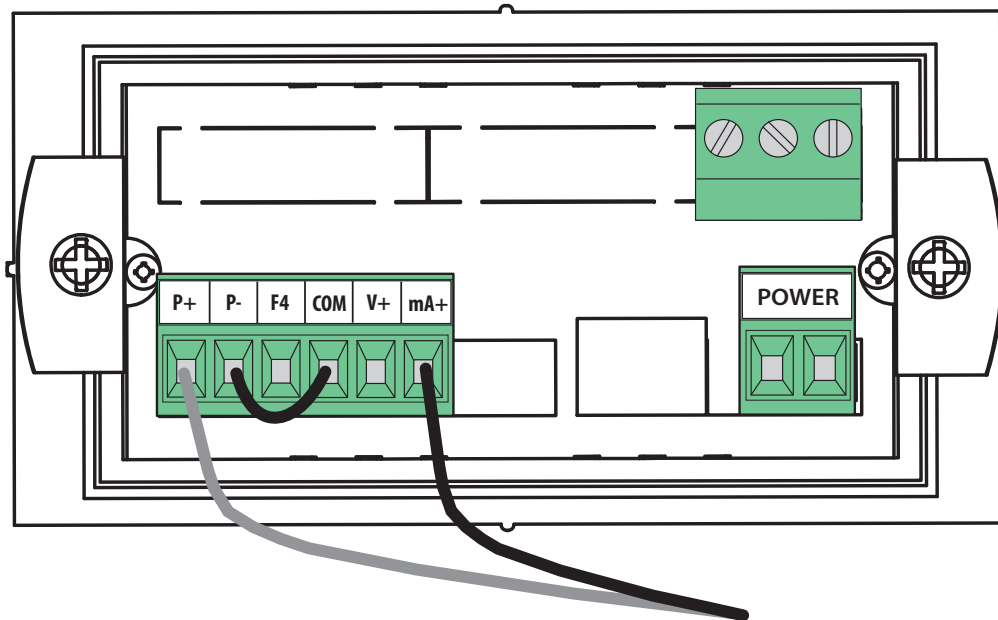

LP1 display module (rear view inside enclosure)

LP1 Model 4650-1 w/ Isolated Analog Output

Power and Signal Connections

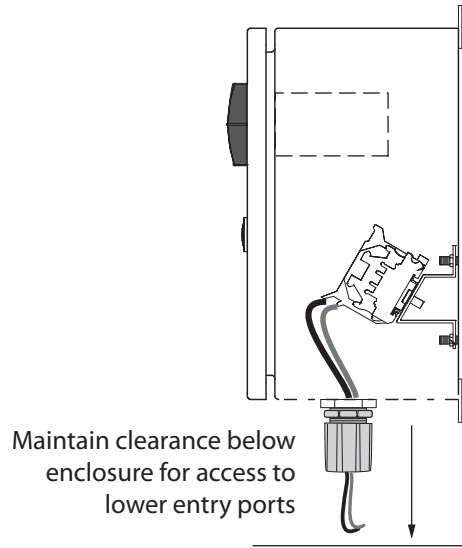
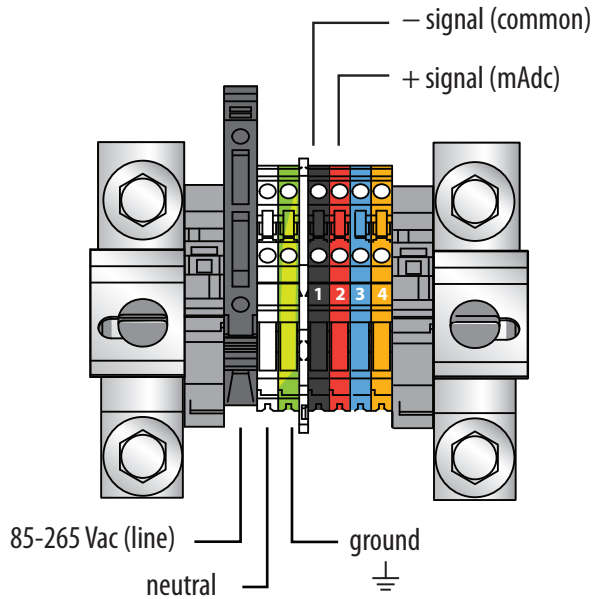

Vac Power Connections

Power connections for the LP1 are provided on the terminal rail within the enclosure. Terminals are provided for 85-265 Vac single phase power for the indicator via a 3-conductor, source grounded cable (line, neutral, ground) The line input block connector is fused with a 6.3A 250V rating.

NOTE – Complete signal (transmitter) connections prior to applying AC power when practical.

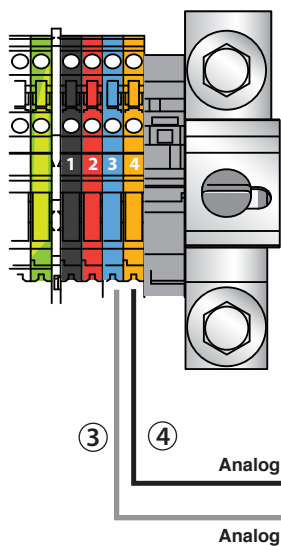

Analog Output (4-20mA)

The LP1 provides isolated analog 4-20mA output. This retransmission signal can represent the full scale reading for an external receiver such as control valve, bar graphs, PLC (analog input). This simplifies integration of other devices since the transmitter input signal does not have to be spanned to the maximum application pressure - the LP1 indicator scales this analog output based on its application programming.

The output must be powered by an **external Vdc source** (12-35 Vdc). Terminal 4 would be connected to +Vdc.

LP1 Model 4650-2 w/ Relay Outputs (SPDT)

Power and Relay Output Connections

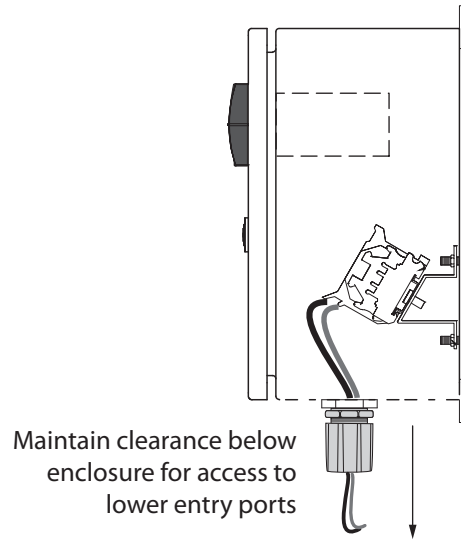
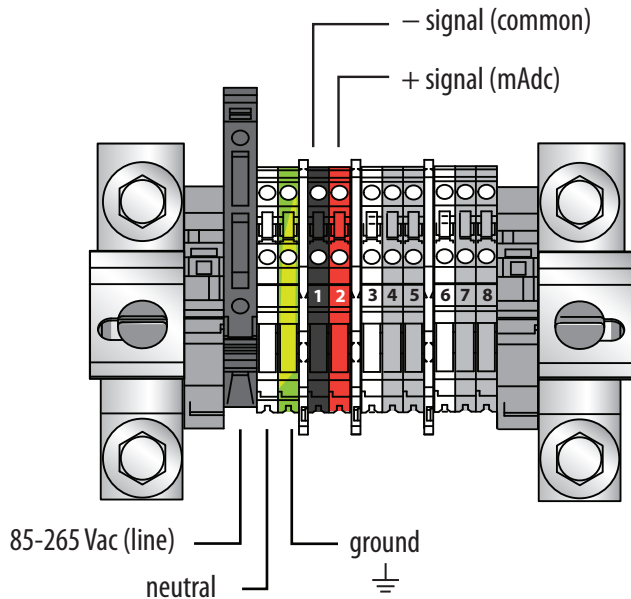

Vac Power Connections

Power connections for the LP1 are provided on the terminal rail within the enclosure. Terminals are provided for 85-265 Vac single phase power for the indicator via a 3-conductor, source grounded cable (line, neutral, ground) The line input block connector is fused with a 6.3A 250V rating.

NOTE – Complete signal (transmitter) connections prior to applying AC power when practical.

Relay Outputs (SPDT)

The LP1 Model 4650-2 provides two SPDT relays for signaling or to control remote equipment such as pumps, valves or alarm functions. The relay contacts are provided as normally-closed, normally-open and common (form C).

When used with inductive loads (AC or DC), please refer to the Application Notes on page 9 for additional considerations.

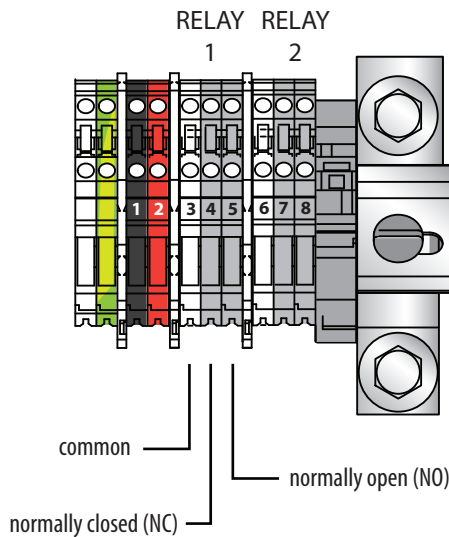

RELAY 1

3	common
4	normally closed (NC)
5	normally open (NO)

RELAY 2

6	common
7	normally closed (NC)
8	normally open (NO)

Signal Input Connections (Two Wire Transmitters)

Signal Input Connection (Vdc Output)

The LP1 digital indicator is designed to supply the necessary excitation to power a typical 2-wire level transmitter.

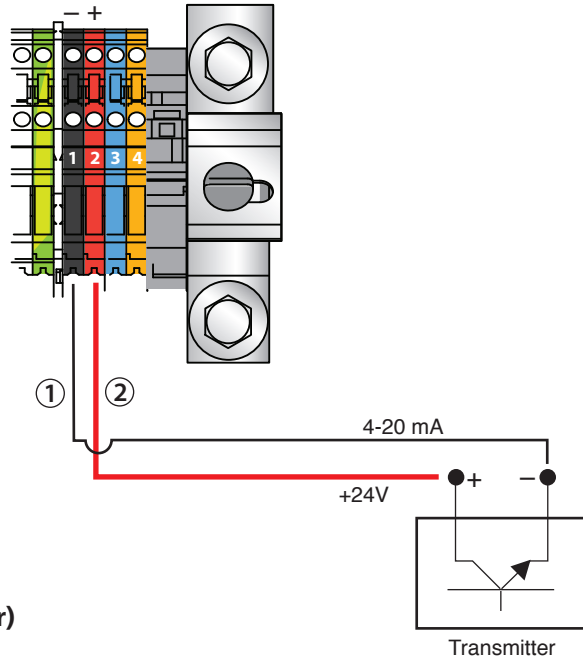

Signal Input Connections (KING-GAGE ES2 Transmitter)

A molded M12 connector and cable is supplied with the KING-GAGE ES2 level transmitter. Refer to the following diagram for completing the signal input connections when using the supplied 4-conductor cable.

The LP1 digital indicator supplies the 24 Vdc excitation to the ES2 transmitter through these connections. (Note: follow the color code as depicted - reversing these connections will result in no power to the transmitter.)

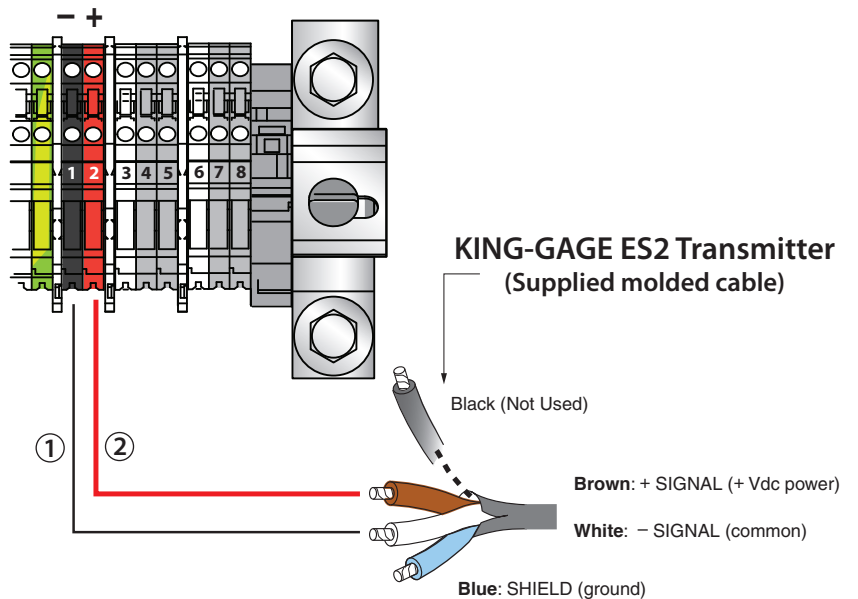

Using LP1 with external Vdc signal loop

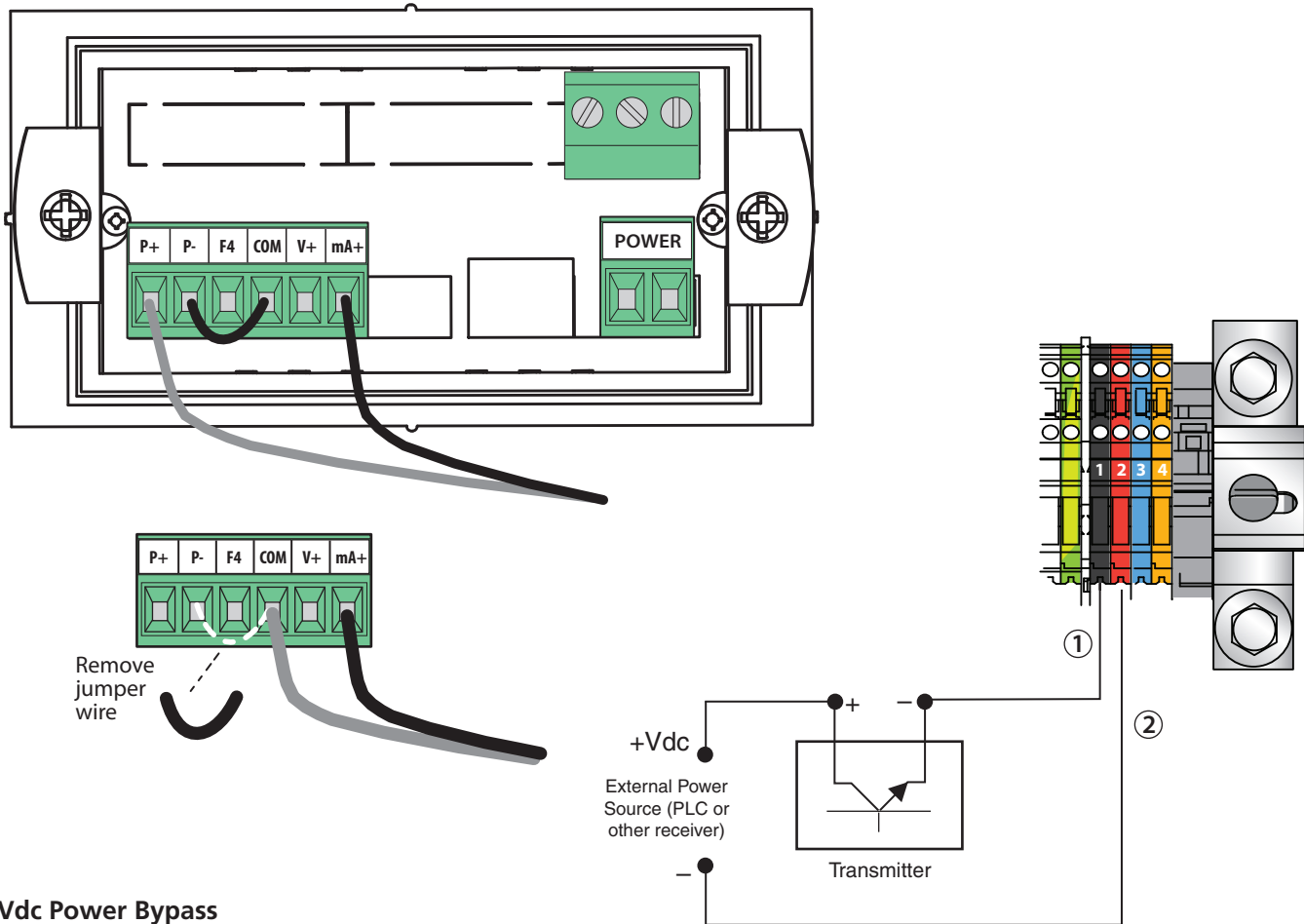

Vdc Power Bypass

The normal (default) setting for the LP1 digital indicator provides 24 Vdc power across the signal input terminals to power the external transmitter. When you use the LP1 indicator in an application where an external Vdc power supply provides excitation to the transmitter (e.g., PLC or other receiver), you must disconnect the power supply jumper at the LP1.

To bypass the internal 24 Vdc power output to the signal loop, open the LP1 enclosure and gain access to the rear of the display module on the door. Refer to the illustrations shown at left.

1. Remove the black jumper wire between the P- and COM terminals on the left hand connector block.
2. Move the red conductor from the P+ terminal and reinstall it into the COM terminal.

Signal Input Connection (External Power)

Maintain the polarity indicated in the diagram above. Terminal 1 should be connected to the - side of the loop. Terminal 2 should be connected in series with the signal loop (which will be the + terminal of the transmitter).

You can check proper continuity by tracing the route of the conductor connected to the + side of the Vdc power source to be sure it is in series with Terminal 2.

Fused Input Terminal (AC Power)

The input block connector is equipped with a fuse element to protect the indicator from power surges. Lift up on the bottom edge of the block to open - this may also be used to disconnect the power to the indicator.

GDC-6.3A fuse
(part no. 7469-4-6.3)

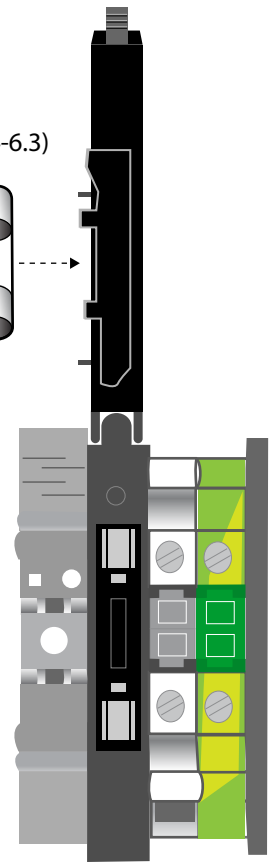
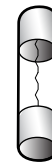

Power Input Terminals

Troubleshooting Checklist

Indicator does not power up.

Check that AC power is connected to the unit. Also check fuse at input block connector (replace if necessary).

Reading does not change.

If the displayed value does not change when tank level changes, check that signal input connections have been completed to the terminal strip located inside of the enclosure.

Inaccurate readings.

The LP1 has been programmed with tank capacity profile based on the previously supplied application data. When used with a pressure-based level transmitter, the specific gravity of the tank liquid was used to calculate the actual volume or weight shown in the reading. If this specific gravity factor is incorrect, the tank level readings will be incorrect.

When the LP1 indicator is used with a direct level measurement transmitter such as a through air or guided wave radar, the placement of the transmitter itself can affect the effective measurement zone. If this varies from the programmed values, the readings may be inaccurate.

If possible, refer to the programming notes or contact our Technical Support at solutions@king-gage.com or 855-367-2494.

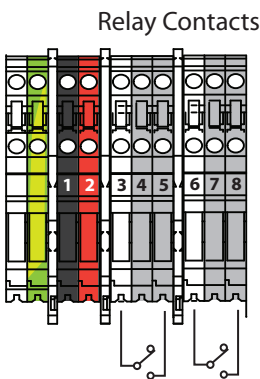

APPLICATION NOTES

Switching Inductive Loads (Relay Outputs)

We recommend the use of suppressors (snubbers) to prevent disrupting the internal microprocessor when the relays are used to switch inductive loads. This will also prolong the service life of the relay contacts.

Suppression can be accomplished with resistor-capacitor (RC) networks implemented by the user with the following guidelines:

R - resistor value 0.5 to 1.0 ohm for each volt across the contacts.

C - capacitor value 0.5 to 1.0 μF for each amp through closed contacts.

Use capacitors rated for 250 VAC.

AC and DC loads protection (using resistor-capacitor network)

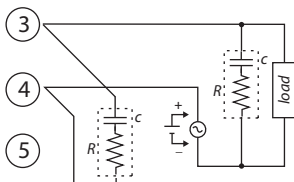

For low voltage DC loads, use a diode with a reverse breakdown voltage two to three times the circuit voltage and forward current at least as large as the load current

Low Voltage DC loads protection

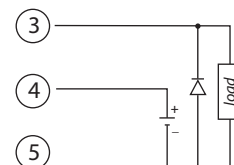

Modbus Communication (Option Module)

The LP1 can provide data output based on Modbus RTU serial communications protocol. For implementation of Modbus, the LP1 must be provided with the Serial Adapter Module (5946) which provides a full or half-duplex RA485 signals.

Use the supplied RJ45 cable to connect the serial adapter module to the M-LINK socket at the rear of the LP1 display inside of the enclosure.

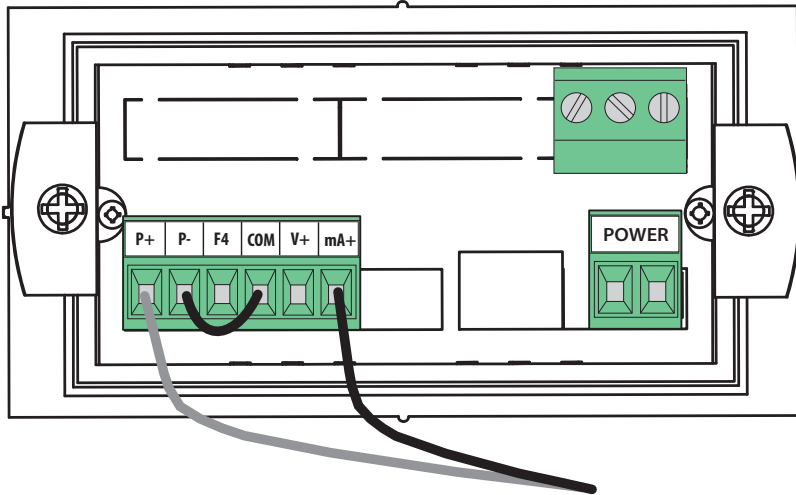

Use the supplied RJ45 cable to connect the serial adapter module (5946) to the M-LINK socket at the rear of the LP1 display.

There are three diagnostic LEDs: power (P) LED indicates when properly powered, transmit data (TX) or data input, and receive data (R) when the adapter is receiving data from the LP1 indicator.

For half-duplex RS485 over a two-wire network, then it is necessary to externally wire the DO to the DI and the \overline{DO} to the \overline{DI} at the screw terminal block (see diagram below).

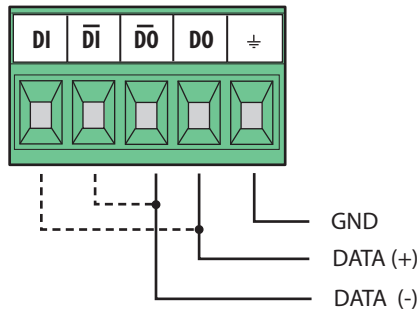

5946 Serial Adapter Module

