

KING-GAGE® Marine Systems

Tank Level and Draft Indicating Systems for the Marine and Offshore Industries

Marine Panel Assemblies

Factory Pre-Assembled Component Installation

- Simplifies Shipboard Installation
- Pre-Assembled Air Line or Signal Wiring
- Heavy Duty Steel Mounting Panels

KING-GAGE®
Column Indicators
(Pneumatic)



Marine tank level gauges and purge controls can be pre-assembled onto steel panels. These panel assemblies include air line tubing, tank label plates, wiring, and terminals as applicable to the specific KING-GAGE components. These pre-fabricated panels can simplify shipboard installation at a reasonable cost. Up to ten individual tank gauges or controls can be supplied on a single panel assembly.

Factory pre-assembly includes all mounting, interconnections, and complete system functional testing prior to delivery. The panels themselves are heavy duty carbon steel treated for corrosion resistance and finished in durable light grey

low gloss polyurethane enamel. Where access space may be limited, smaller panel sections can be provided that are later joined together to form a larger overall assembly.

Certified System Drawings

Factory will provide certified plan drawings for gauge or indicator panels specified on an order. These plan drawings note tank assignments, sequence from left-to-right, maximum depth and/or reserve dimensions, and individual component model numbers. Plan drawings can further assist the scheduling process by verifying equipment specifications prior to release to manufacture.

Note that certified drawings may be provided at additional cost for orders specifying control panels only.

Marine Panel Selections

Marine panel assemblies are available in four variations. Up to eight (8) individual system components may be included on one panel section (multiple sections may be joined). It should be noted that pneumatic column indicator panels vary in overall height based on largest indicator range incorporated on panel.

KING-GAGE Column Indicator (Pneumatic)

Carbon steel panel with all gauges mounted and functionally tested. SafeGard overpressure units, if applicable, are mounted and adjusted to the appropriate settings. Includes compressed air supply manifold assembly (if applicable) and individual tank label plates.

KING-GAGE LevelBAR Indicator

Carbon steel panel with all indicators mounted and functionally tested. All power and signal connections are prewired to junction box terminal block(s) with wire ducts and water resistant connectors. Individual tank label plates.

For details about the electronic LevelBAR indicators, refer to Marine Systems **Supplement 9130**.

KING-GAGE Purge Controls (Pneumatic)

Carbon steel panel with all purge controls mounted and functionally tested. SafeGard overpressure units, if applicable, are adjusted to the appropriate settings. Includes compressed air supply manifold assembly and individual tank label plates.

For details about the LiquiSeal Purge Control refer to Marine Systems **Supplement 9110**. For details about the Model 780 Purge Control refer to **Supplement 9120**.

KING-GAGE D/P Purge Controls (4–20 mA)

Carbon steel panel with all purge controls mounted and functionally tested. All power and signal connections are prewired to junction box terminal block(s) with wire ducts and water resistant connectors. Includes compressed air supply manifold assembly and individual tank label plates.

For details about the D/P LiquiSeal transmitters refer to Marine Systems **Supplement 9110**. For details about the D/P Purge Control transmitter, refer to **Supplement 9120**.

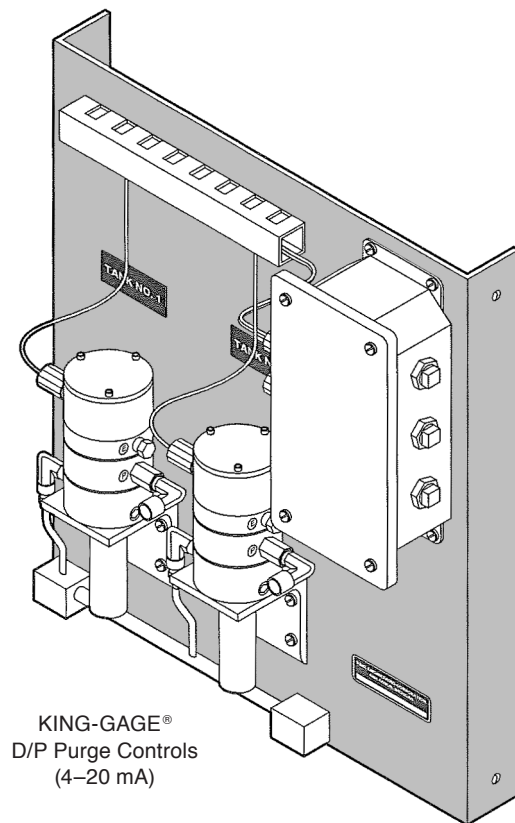

KING-GAGE®
D/P Purge Controls
(4–20 mA)

Specifications

Base Material

H.R. carbon steel, 11-gauge or
Brushed stainless steel, type 304, 11-gauge

Finish

Gray enamel paint, or brushed SS

Number of Systems

Maximum of eight (8) installed components (indicators or controls) per panel section.

KSE Corporation
600 W. Germantown Pike Suite 400
Plymouth Meeting, PA 19462
(610)-768-8922
www.ksecorp.com

KING-GAGE LevelBAR Indicators

Carbon Steel (11-gauge) treated to prevent corrosion finished with durable light grey paint. All indicators are mounted and functionally tested. All power and signal connections are prewired to junction box terminal block(s) with wire ducts and water resistant connectors. Individual tank label plates.

Specifications

Base Material

H.R. carbon steel, 11-gauge or
Brushed stainless steel, type 304, 11-gauge

Finish

Gray enamel paint, or brushed SS

Number of Systems

Maximum of eight (8) installed indicators per panel section.

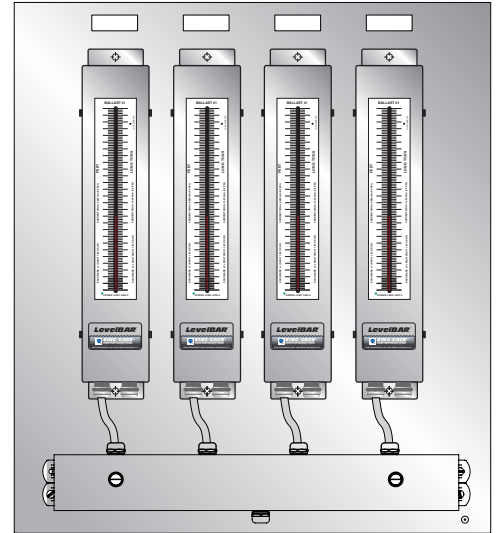

LevelBAR Column Indicator Panel

KING-GAGE LP2 Digital Indicators

Carbon Steel (11-gauge) treated to prevent corrosion finished with durable light grey paint. All indicators are mounted and functionally tested. All power and signal connections are prewired to junction box terminal block(s) with wire ducts and water resistant connectors. Individual tank label plates.

Specifications

Base Material

H.R. carbon steel, 11-gauge or
Brushed stainless steel, type 304, 11-gauge

Finish

Gray enamel paint, or brushed SS

Number of Systems

Maximum of four (4) installed indicators per panel section.

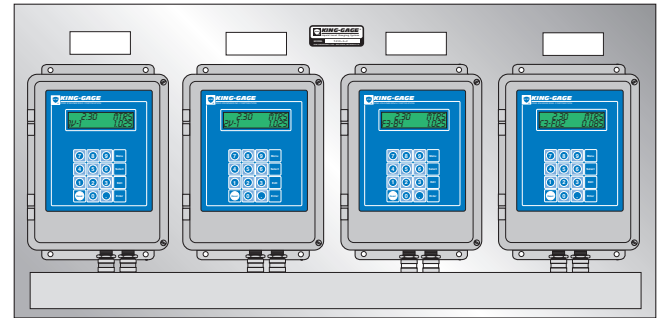

LP2 Indicator Panel

KING-GAGE LP3 System Display

Stainless steel (11-gauge) brushed panel is recommended - carbon steel available. LP3 system enclosure (SS) houses all power and signal connections. Supplied with water resistant connectors.

Specifications

Base Material

H.R. carbon steel, 11-gauge or
Brushed stainless steel, type 304, 11-gauge

Finish

Brushed SS (standard) or gray enamel paint (carbon steel base material)

Number of Systems

One (1) LP3 Display System with SS enclosure on panel.



LP3 Indicator Panel

KING-GAGE® Marine Systems

KING-GAGE® Tank D/P Purge Controls (4–20 mA)

Carbon Steel (11-gauge) treated to prevent corrosion finished with durable light grey paint. All purge controls are mounted and functionally tested. All power and signal connections are prewired to junction box terminal block(s) with wire ducts and water resistant connectors. Includes compressed air supply manifold assembly and individual tank label plates.

Specifications

Base Material

H.R. carbon steel, 11-gauge or
Brushed stainless steel, type 304, 11-gauge

Finish

Gray enamel paint, or brushed SS

Number of Systems

Maximum of eight (8) installed components (indicators or controls) per panel section.

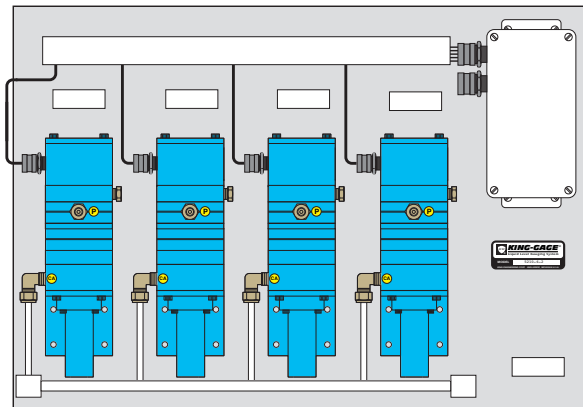

Panel

KING-GAGE® Tank Purge Controls (Pneumatic)

Carbon Steel (11-gauge) treated to prevent corrosion finished with durable light grey paint. All purge controls are mounted and functionally tested. SafeGard overpressure units, if applicable, are adjusted to the appropriate settings. Includes compressed air supply manifold assembly and individual tank label plates.

Specifications

Base Material

H.R. carbon steel, 11-gauge or
Brushed stainless steel, type 304, 11-gauge

Finish

Gray enamel paint, or brushed SS

Number of Systems

Maximum of eight (8) installed components (indicators or controls) per panel section.

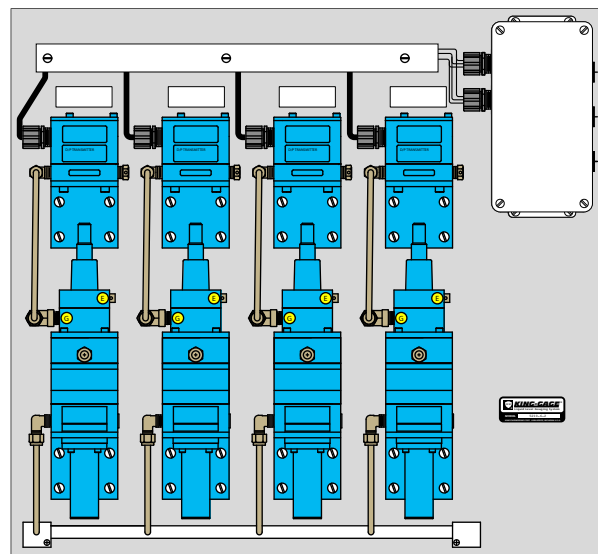

Panel



KSE Corporation
600 W. Germantown Pike Suite 400
Plymouth Meeting, PA 19462
(610)-768-8922
www.ksecorp.com

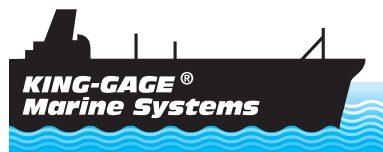

www.king-gage.com

© KING-GAGE and the KE emblem are registered trademarks of King Engineering Corporation, Berea, OH USA

All specifications are subject to change without notice.
© 2011 King Engineering Corporation, all rights reserved.