

Service Parts & Dimensions – 1060-26.00

Effective: October, 2010

King AcraSensor II Diaphragm Units Model Numbers – 8999-1-4, 8999-2-4, 8999-3-4

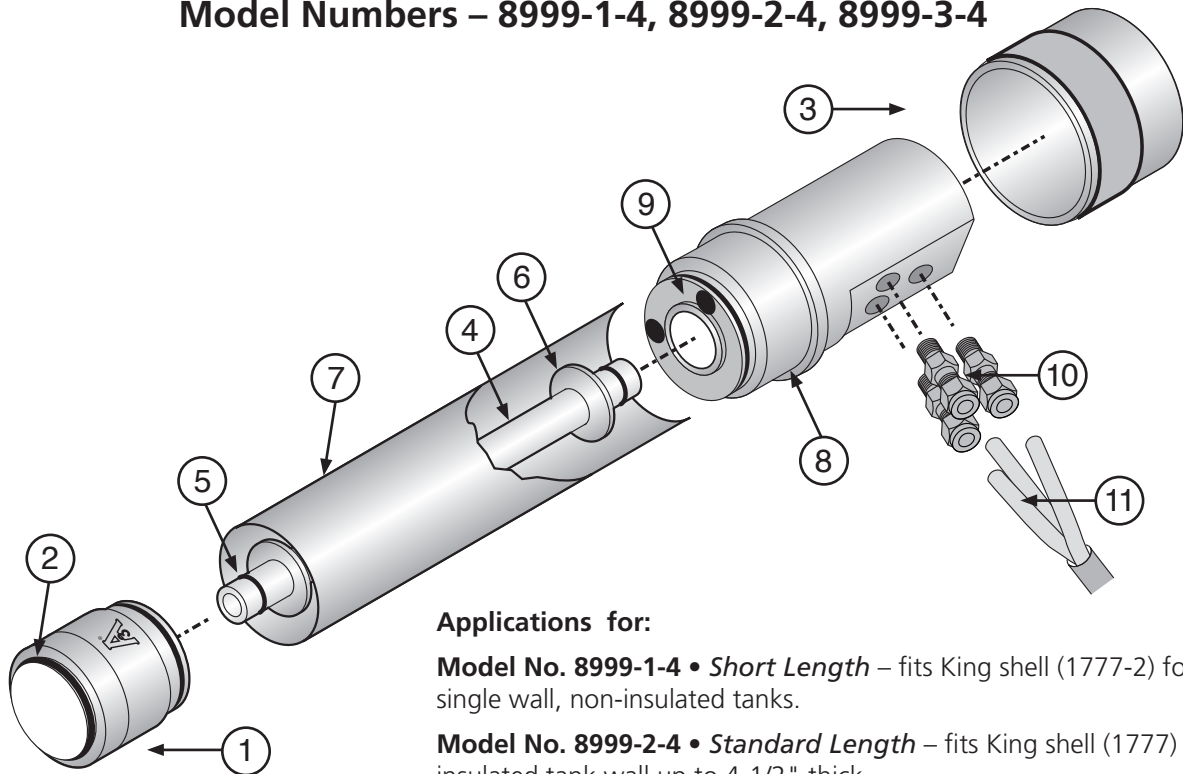

Applications for:

Model No. 8999-1-4 • Short Length – fits King shell (1777-2) for single wall, non-insulated tanks.

Model No. 8999-2-4 • Standard Length – fits King shell (1777) for insulated tank wall up to 4-1/2" thick.

Model No. 8999-3-4 • Long length – fits King shell (1777-3) for insulated tank wall up to 6-3/4" thick.

Item	Description	Model No. 8999-1-4	Model No. 8999-2-4	Model No. 8999-3-4
1	Titanium sensing diaphragm (includes item 2)	7904-1	7904-1	7904-1
2	Replacement silicone O-ring	6554-40	6554-40	6554-40
3	AcraSensor nut	1751	1751	1751
4	Post assembly (includes items 5 & 6)	7859-1	7859-2	7859-3
5	O-ring (2 required)	6554-7	6554-7	6554-7
6	Spring washers (2 required)	3038	3038	3038
7	Housing	5611-21	5611-22	5611-23
8	Replacement connector kit (includes items 9 & 10)	1752-30-3	1752-30-3	1752-30-3
9	O-ring	6495-222	6495-222	6495-222
10	1/8 NPT x 1/4 tube fitting, stainless steel (3 required)	8475-22	8475-22	8475-22
11	3-tube cable (15 ft. length)	1766-15	1766-15	1766-15
	3-tube Cable (per foot)	8014-xx	8014-xx	8014-xx

3-tube cable (item 11) is available in standard 15 ft. length (p/n 1766-15). For lengths over 15 ft., order p/n 8014-x and specify total length (in feet) required (-xx represents number of feet specified).

Dimensional Data:

Short (8999-1-4)

- Overall length 4 inches

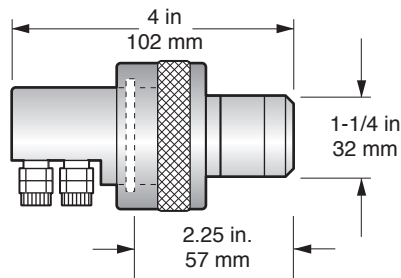

Standard (8999-2-4)

- Overall length 8-3/8 inches

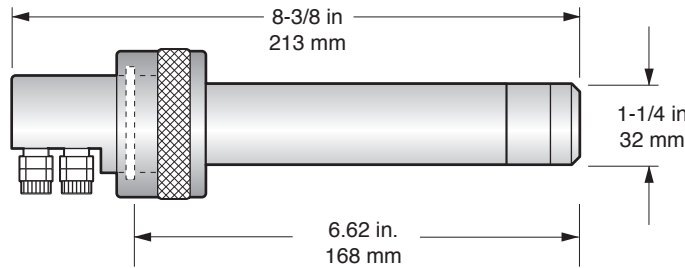

Long (8999-3-4)

- Overall length 10-5/8 inches

