

Service Parts & Dimensions – 1060-25.16

Effective: September, 1999 (Replaces December, 1998)

King AcraSensor Filler Level Sensor Model Number S-1673

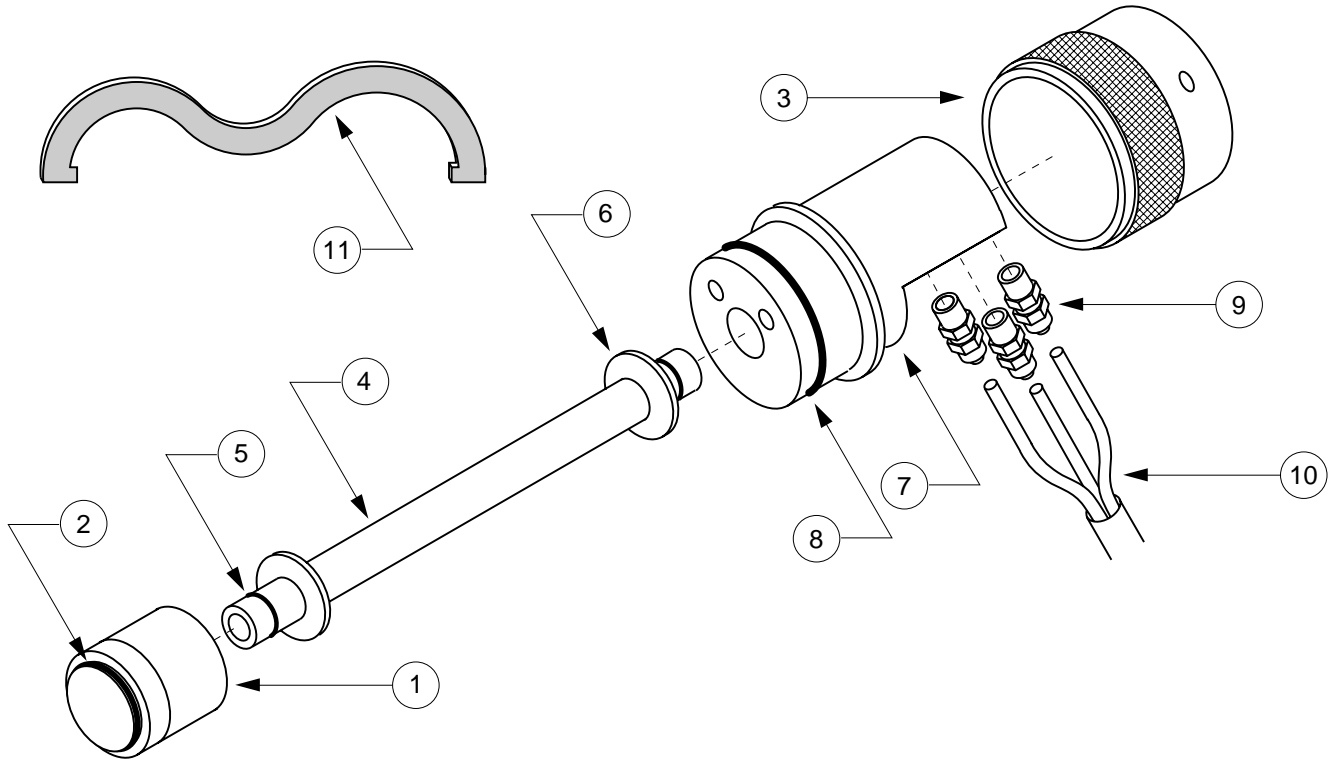

Item	Description	Part No.	Notes
1	Metal Sensing Diaphragm	7904-1	1
2	Replacement Silicone O-Ring	6554-40	1
3	AcraSensor Nut	1751	-
4	Post Assembly	S-1673-3	2
5	O-Ring (2 required)	6554-7	2
6	Spring Washers (2 required)	3038	2
7	Replacement Connector Kit	1752-22-3	3
8	O-Ring	6495-24	3
9	PolyFlo Fitting (1/8: NPT x 1/4" O.D. Tube	1543-1	3
10	3 -Tube Cable (15 ft. length)	1766-15	4
11	Spanner Wrench	7881	5

See
reverse
side for
notes

Notes:

1. Sensing Diaphragm, p/n 7904-1 (item 1) includes O-Ring (item 2).
2. Post Assembly (item 4) includes O-Rings (item 5) and Spring Washers (item 6).
3. Replacement Connector Kit, p/n 1752-22-3 (item 7) includes O-Ring (item 8) and Fittings (item 9).
4. 3-Tube Cable (item 10) is available in standard 15 ft. length (p/n 1766-15). For lengths over 15 ft., order p/n 8014-x and specify total length (in feet) required (- x represents number of feet specified).
5. Spanner Wrench (item 11) is shipped with new Diaphragm units. If additional wrenches are desired, order p/n 7881. It is used to tighten the AcraSensor nut, which is provided with torque parts to accommodate the wrench.

Dimensional Data:

