

# Service Parts & Dimensions – 1010-24.10

Effective: September, 1999 (replaces February, 1998)

## TeleSensor Diaphragm Unit External Mounting - Base No.'s 922, 923 & 924

### Part Number Key -

92x-xxx

#### Flange Size

- 2 - 2 in. nominal pipe ANSI, 150-lb.
- 3 - 3 in. nominal pipe ANSI, 150-lb.
- 4 - 4 in. nominal pipe ANSI, 150-lb.

Dash No.	Flange	Diaphragm
11x	carbon steel	titanium
12x	carbon steel	silicone rubber
13x	carbon steel	buna-N
31x	304 stainless st	titanium
32x	304 stainless st	silicone rubber
33x	304 stainless st	buna-N
71x	316 stainless st	titanium
72x	316 stainless st	silicone rubber
73x	316 stainless st	buna-N
91x	PVC	titanium
92x	PVC	silicone Rubber
93x	PVC	Buna-N

x - final digit specifies connections. 1 = 1/4 NPT, 3 = 1/4 PolyFlo, 4 = 1/4 Hi-Duty

### Dimensions -

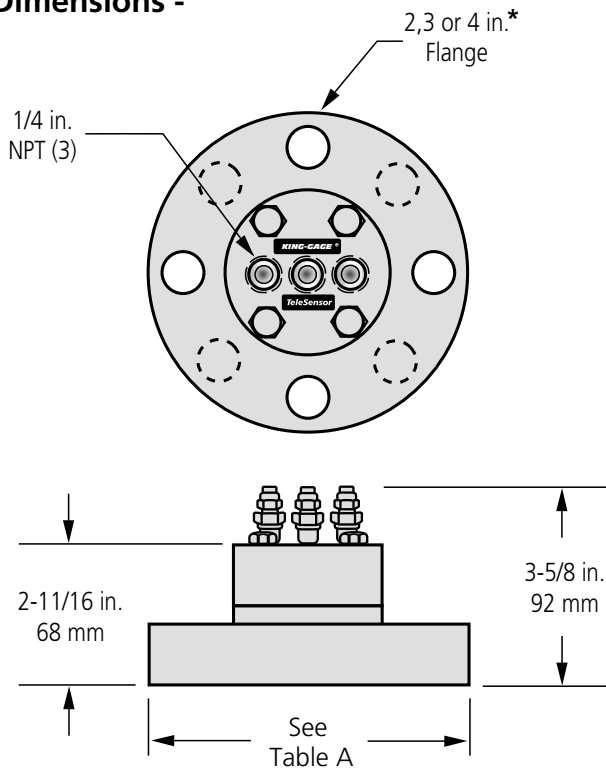

Table A -

Base	Flange Size	Diameter
922-	2 in. 150-lb B.16 ANSI	6.0 in./ 153 mm
923-	3 in. 150-lb B.16 ANSI	7.5 in./ 191 mm
924-	4 in. 150-lb B.16 ANSI	9.0 in./ 229 mm

\* 4 in. Flange has 8 bolt circle,  
2 and 3 in. Flange have 4 bolt circle.

**Service Parts - Base No.'s 922,923 & 924:**

ITEM	PART NO.	DESCRIPTION	QTY	NOTES
1.	8279-9	Hex cap screw 1/4-20 x 1.5 in.	4	
2.	2515-9	Split ring lockwasher 1/4	4	
3.	6554-45	O-ring	2	I.
4.	7859-1	Post assembly	1	II.
5.	7904-1	Titanium diaphragm assy.		III.
	S-1464-7-66	Teflon-coated diaphragm assy.		
	S-1662-1	Kingkote hardened diaphragm assy.		
5a.	7899-3	Diaphragm body (use w/ 5b.)		IV.
5b.	6448-12	Molded silicone diaphragm		IV.
	6448-23	Molded buna-N diaphragm		
6.	3029S-6	Socket head cap screw 10-32 x 0.75 in.	4	
7.	2515-7	Split ring lockwasher #10	4	

**Notes**

- I. Used for for upper and lower seal as shown.
- II. Assembly includes O-rings (6554-7) and spring washers (3038).
- III. Metal diaphragm assemblies are unitized construction. Includes O-ring (6554-40).
- IV. Molded elastomer diaphragms are installed over diaphragm body (Item 5a). Silicone diaphragm is white, buna-N diaphragm is black in appearance.

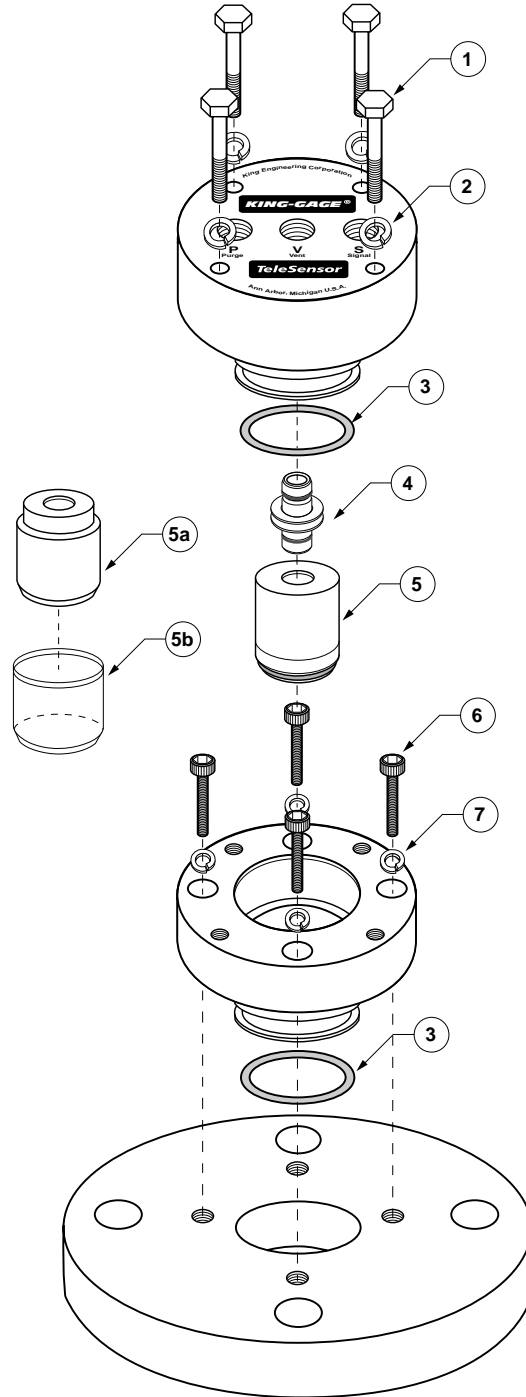

**Reference Documentation -**

- EX-1525-1 ..... Troubleshooting Guide; TeleSensor Systems
- K-1020-1-922 ..... Installation Instructions - External Mount TeleSensor

® King-Gage and the KE emblem are registered trademarks of King Engineering Corporation, Ann Arbor, Michigan, U.S.A.  
 All specifications are subject to change without notice  
 © 1999 King Engineering Corporation. All rights reserved