

TeleSensor™

TeleSensor Liquid Level Pressure Sensors



Troubleshooting Manual for Gauging Systems with King-Gage Pneumatic Sensors.

(Also applies to systems using
D/P Transmitter option for 4-20 mA output)

© 2000 King Engineering Corporation. All rights reserved.

The information contained in this manual was accurate at the time of release. Specifications are subject to change without notice.

Warranty - All King Engineering products are guaranteed to be free from defects in material and workmanship for one year from the date of purchase. Any product or part found to be defective under normal use within one year of purchase will be repaired or replaced at no charge if returned to the company at Ann Arbor, Michigan within ten days of discovery of the defect. No other warranties, whether expressed, implied or statutory, including the warranties of fitness for a particular purpose or merchantability, are given by this agreement. The exclusive remedy for nonconformity of these goods shall be repair and/or replacement of the nonconforming goods or parts.

Seller will not be liable for consequential damages resulting from breach of this agreement. The term "consequential damages" shall include but shall not be limited to damage to all machines, equipment and goods other than the goods sold hereby, interruption of production, loss of profits, delays of any kind, administrative expense and overhead.

Revisions:

- (A) May, 1979 – Original Release.
- (B) September, 1988 – Revised and Expanded w/ New Format.
- (C) February, 1996 – Revised, 860-Series Controls Updates.
- (D) July, 1998 – Address Correction
- (E) March, 2000 – Revised

Contents -**External TeleSensor - Flange Mount Diaphragm Sensor**

External TeleSensor Unit	Page 4
Complete Package (with Sensor Control)	Page 6

Internal TeleSensor - Flange Mount Extended Diaphragm Sensor

Internal TeleSensor Unit	Page 5
Complete Package (with Sensor Control)	Page 6

Optional 4-20 mA Electronic Output Version Page 7**Preliminary - Operational Requirements**

Tube Connections, Compressed Air Supply	Page 8
Troubleshooting Checklist	Page 8

Troubleshooting and Problem Diagnosis

Symptom #1 - High Reading (Empty Tank)	Pages 9
Symptom #2 - Negative Reading	Page 10
Symptom #3 - High Reading (Full Tank)	Pages 11
Symptom #4 - Low or No Reading (Full Tank) ..	Pages 12
Symptom #5 - Reading Stops Rising	Page 13
Symptom #6 - Overpressure Condition	Page 13
Symptom #7 - Fluctuating/Bouncing Reading ...	Page 14

Addendum - Obsolete Version TeleSensor Units

2-Line Version with Air Control	page 14
2-Line Version with Air Snubber Screw	Page 14

Reference Documentation -

K-1020	Installation Instructions, External TeleSensor
K-1030	Installation Instructions, Internal TeleSensor

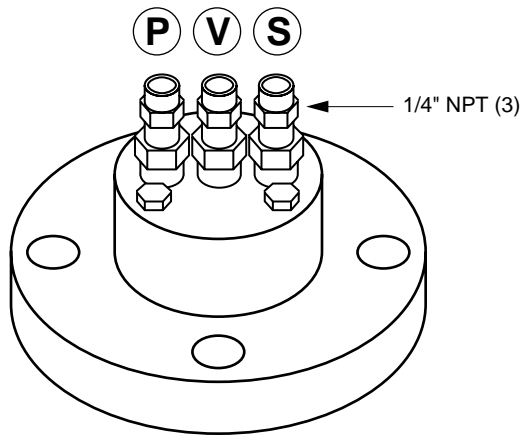

Top View

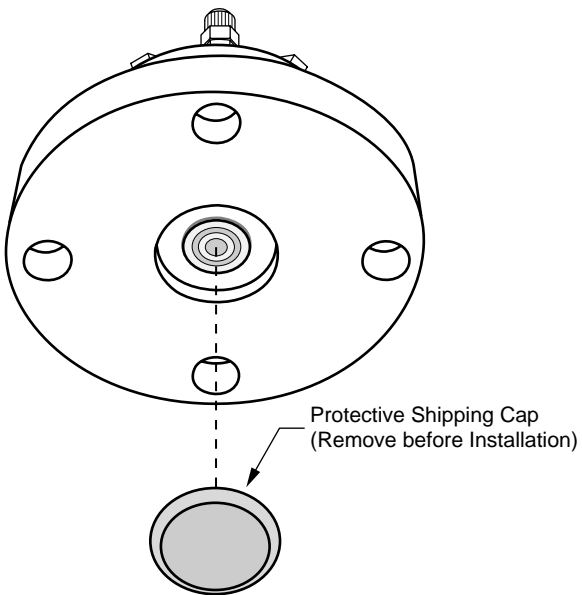

Bottom View

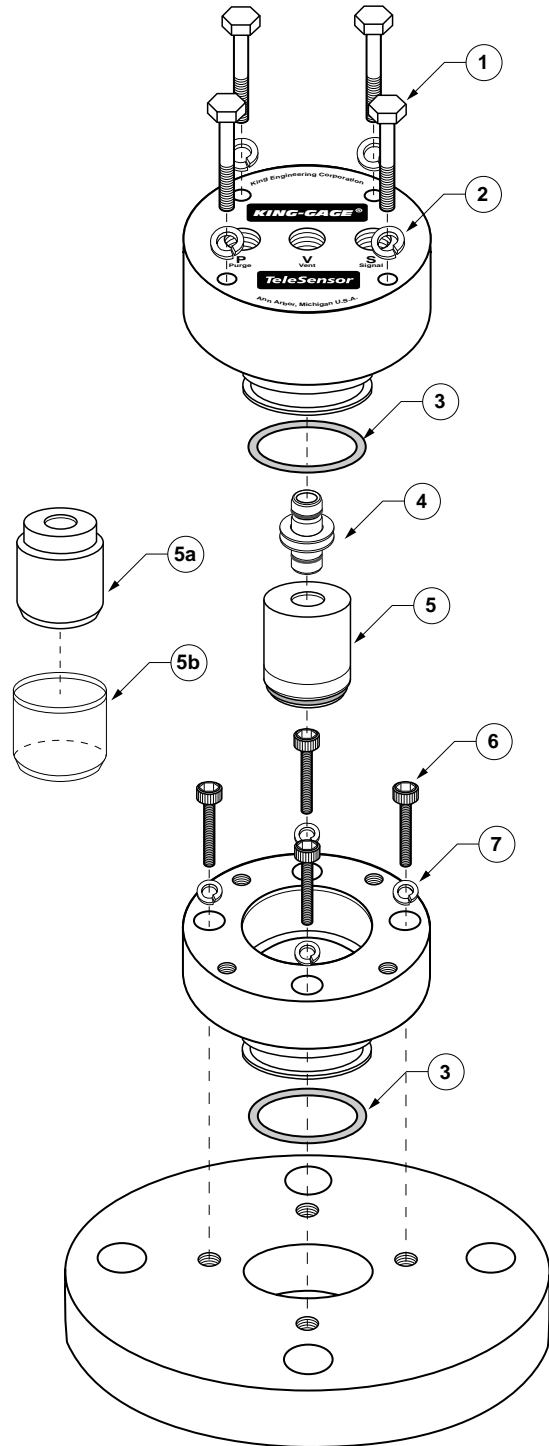

TeleSensor Diaphragm Units

These sensor packages work on the force balance principle. A sensitive diaphragm is exposed to the liquid contents of a tank (hydrostatic pressure). Compressed air pressure is generated within the sensor resulting in a 1:1 balance between these two pressures. The pneumatic output can either be routed to an appropriate indicator, or can be converted to a proportional electronic signal using a D/P transmitter.

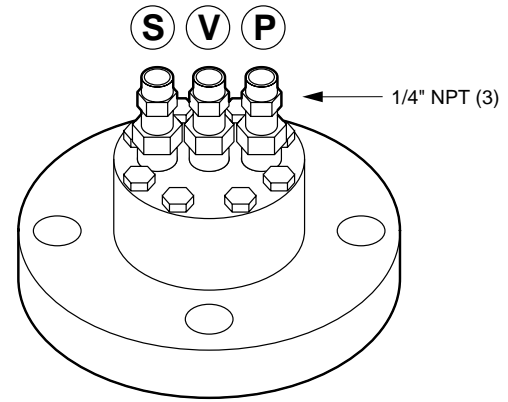
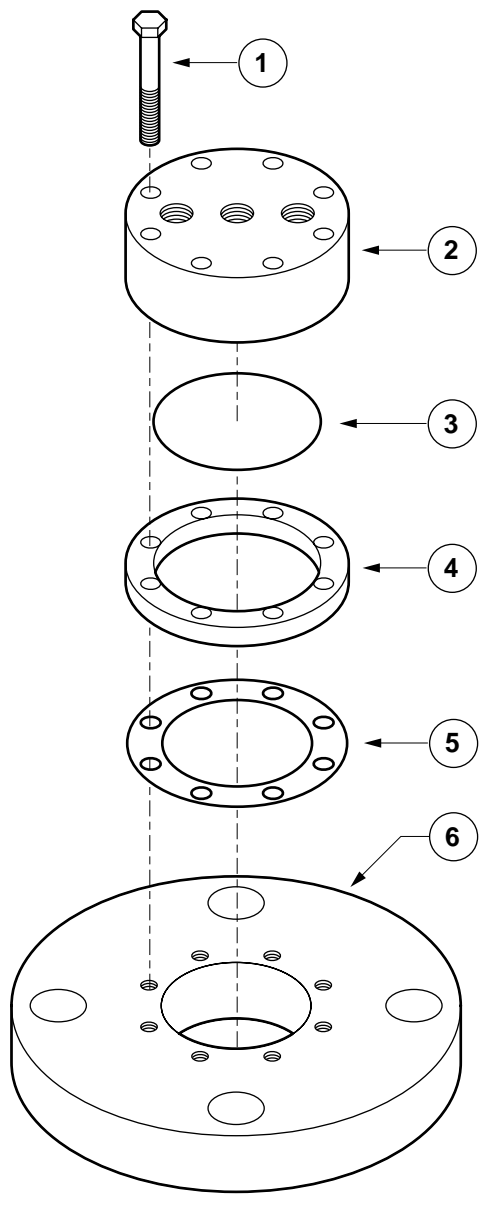

Top View

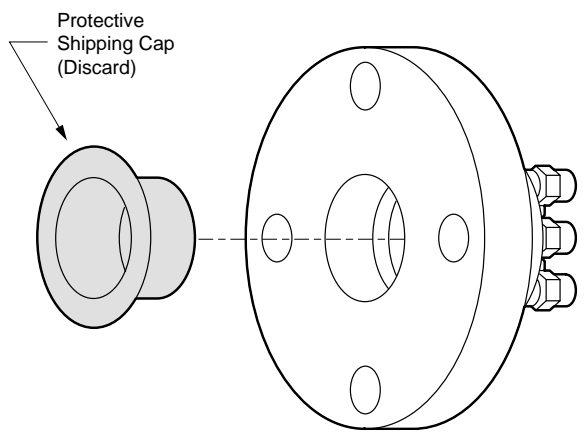

Bottom View

Internal Mount TeleSensor

This version utilizes a diaphragm capsule that extends into the tank. Designed for mating to existing connections on top, side or bottom of tank. Specifically recommended for liquids that have a tendency to “set-up” when confined within a tank nozzle. This configuration may also be used as an alternative method of installation when lower tank openings are prohibited or impractical (such as with an underground tank).

Optional Multi-Section Construction - The illustration below depicts multi-sectional units available when clearance is inadequate for installation of the Internal TeleSensor. Unit can be separated at each flange junction and re-assembled during installation/removal.

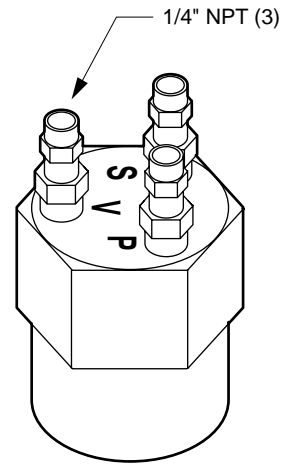

Tubing Connections

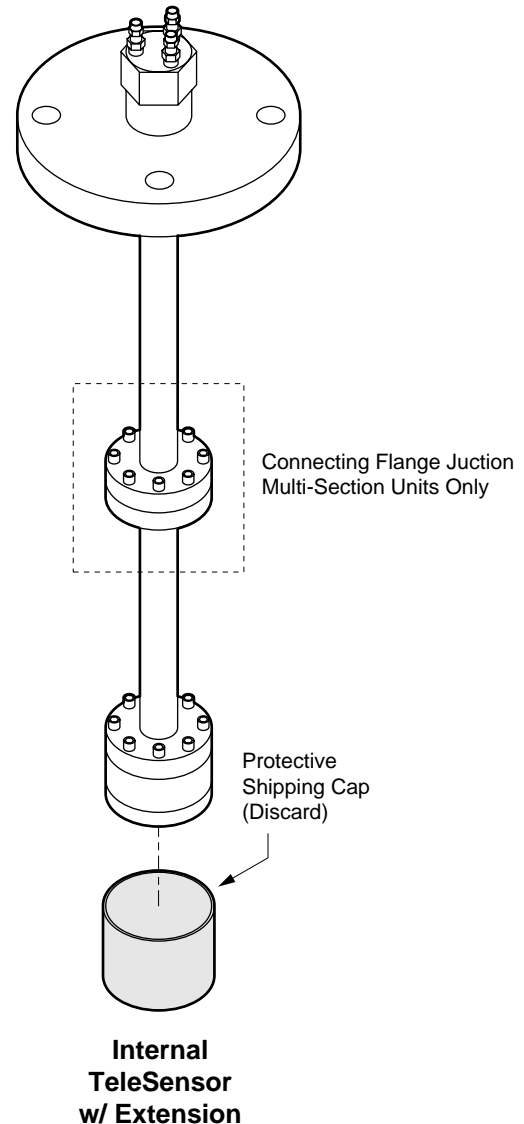
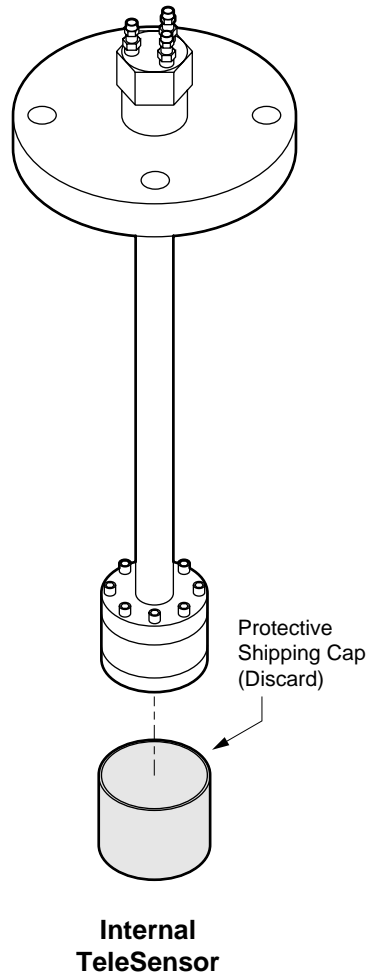

Complete Sensor Package - Pneumatic Output

TeleSensor pneumatic diaphragm sensors are used in conjunction with either current 860-series Sensor Controls or 760-series (discontinued). A compressed air supply must be connected to the Sensor Control for operation of the pneumatic sensor. The interconnecting tubing between the sensor at the tank and the control unit must be leak-tight. Even a slight leak at one of the tube fittings can affect the pneumatic output from the sensor.

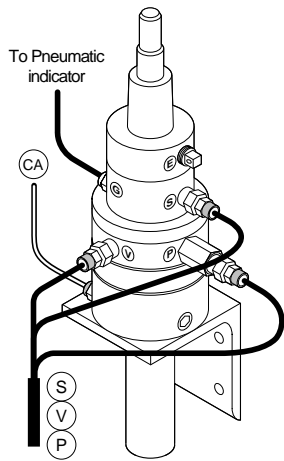

Model 860 Control with SafeGard Option

SafeGard Option

This is an adjustable pressure limit control used to protect the readout device from being subjected to pressures beyond its range. It can be field adjusted to increase or decrease the pressure limit setting to suit the range of the readout device. (SafeGard Sensor Controls are tagged with factory preset value when shipped to customer.)

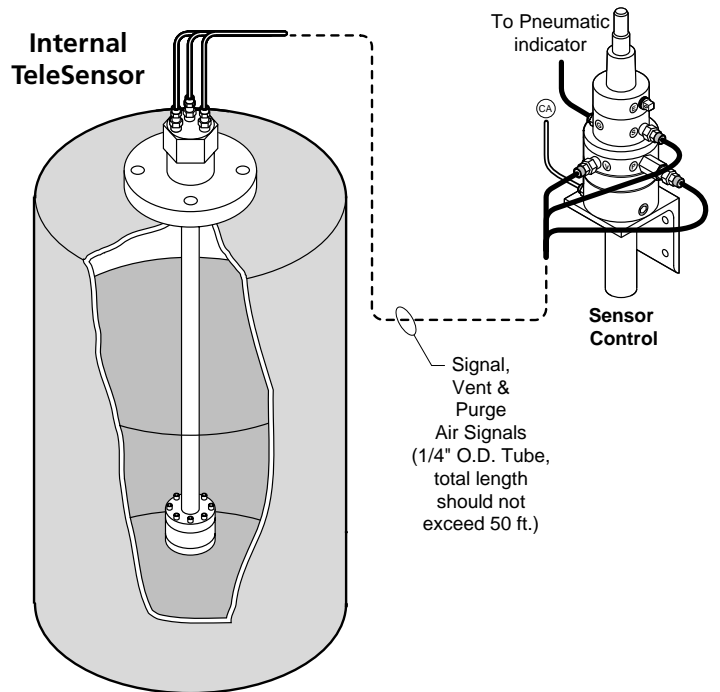
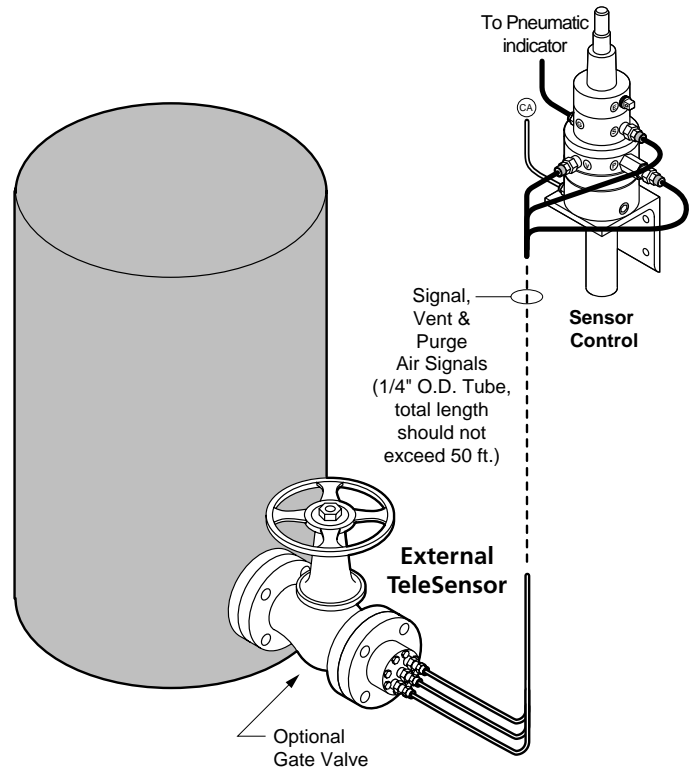

Complete Sensor Package - Pneumatic Output, External TeleSensor (top), Internal TeleSensor (bottom)

**Complete Sensor Package -
Electronic 4-20 mA Output**

TeleSensor diaphragm unit may also be used in conjunction with a D/P Sensor Control to provide a direct 4-20 milliamp signal for process control or remote level indication. A compressed air supply must be connected to the D/P Sensor Control for operation of the pneumatic sensor. The interconnecting tubing between the sensor at the tank and the control unit must be leak-tight. Even a slight leak at one of the tube fittings will affect the accuracy of the output signal.

Combined Pneumatic and 4-20 mA Output -

A tee fitting can be installed in the 'S' port of the D/P Sensor Control to provide a pneumatic output signal for a KING-GAGE column indicator in addition to the 4-20 mA output from the integral electronic transmitter.

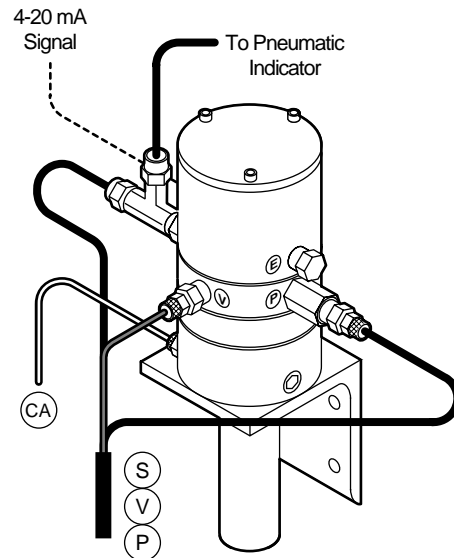

**Model 868 D/P Sensor Control
with Tee Fitting**

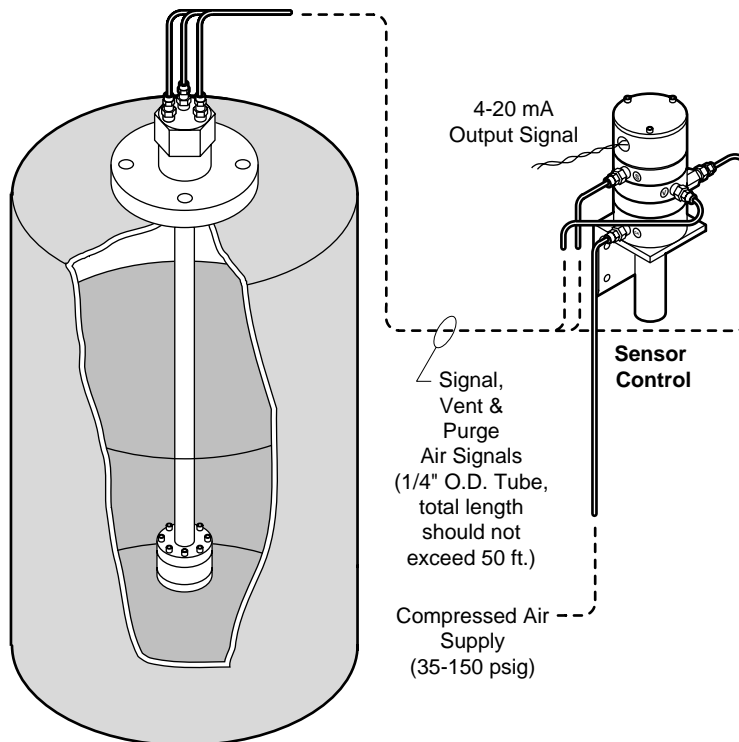

Complete Sensor Package - Electronic 4-20 mA Output

Preliminary - Operational Requirements

■ Compressed Air Supply

Make certain that air supply to Sensor Control is turned on. Also check that supply pressure is set to a minimum of 35 PSIG. The supply line must provide clean, dry and oil-free air to the Sensor Control. This equipment must not be used in conjunction with an in-line lubricator, since even clean oil will foul the internal flow orifices of the Sensor Control.

To determine the supply pressure required for proper operation of the TeleSensor system, refer to the following calculation:

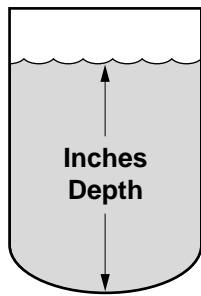

$$\text{inches depth} \times \text{specific gravity} \times .0361 + 20 = \text{min. PSIG}^*$$

* **Note** - Minimum supply pressure not less than 35 PSIG.
Maximum supply pressure not to exceed 150 PSIG.

■ Tubing Connections

Check that interconnecting tubing is properly installed at the Sensor Control and TeleSensor diaphragm unit. The individual tubes should be interconnected between similarly designated ports:

Sensor Control	TeleSensor
"P" (purge air)	"P" (purge inlet)
"V" (vent).....	"V" (exhaust vent)
"S" (pressure signal)	"S" (pressure signal)

Unless a D/P Sensor Control with 4-20 mA output is used, a gauge pressure connection ("G") is provided for routing the pneumatic signal to an appropriate indicator.

Troubleshooting Checklist

The following listing outlines some basic troubleshooting procedures to follow when the sensor does not operate or inaccurate operation is suspected.

More detailed troubleshooting procedures are covered in following sections of this manual.

No Output Signal

Check that compressed air supply is turned on and tubing is completely connected to sensor and control unit.

(D/P Sensor Controls Only - Check that two conductor wiring has been connected to transmitter terminals and indicator or other source of Vdc electrical power.)

Low Output Signal

Check that sensor control has adequate compressed air supply pressure. Refer to 'Operational Requirements' at left for supply pressure requirements. Another possibility is that leaks may exist in tubing or at connections between sensor and control unit.

(D/P Sensor Controls Only - Cause may be that the load resistance on the signal loop exceeds the capacity of the power supply. If practical, measure total resistance through the signal loop wiring.

High Output Signal

Possible restriction in vent tube or internal vent of sensor control. Disconnect vent tube at sensor control 'V' port and check sensor output. If output signal decreases, servicing of sensor control may be required. If there is no effect on output signal, check entire length of tube for any kinks or evidence of liquid contamination.

Other causes may include: Venting capacity of tank is exceeded by rapid fill rate (check that vent is open and unobstructed - dirty screen may restrict vent).

Also, tank agitation may be directing product flow against diaphragm. This can be verified by stopping agitation and checking sensor output.

Product Leakage

Diaphragm may be ruptured due to physical damage, exposure to incompatible chemicals, or restriction in sensor vent tube. Another possibility is that the sealing gasket (supplied by others) between the flanges has deteriorated.

Detailed Troubleshooting Procedures

When the gauging system is not functioning properly, the individual components should be isolated and tested separately. However, the first step should be to check that system components have been properly installed and all connections (pneumatic tubing/electrical wiring) have been completed.

Symptom No. 1 High Reading (Tank is Known to be Empty)

This condition is defined as having a slight reading of product present in the tank, even though tank is known to be completely empty. This may also be referred to as a high "air-on" reading.

1-1. Check for vent restriction by removing tube from "V" port of the Sensor Control. If the reading drops, this may indicate a restriction within the backpressure regulator, or perhaps that the small vent hole at the rear of the control is obstructed. (Under normal operating conditions, removing the vent tube may cause a noticeable rise in the readings on a column indicator or digital indicator.)

1-2. If the vent tube is disconnected, check for signs of moisture (tank product or condensation). Even a slight amount of liquid can cause restriction within the vent tube. If present, determine whether it is due to product leakage (broken diaphragm) or condensation from the air supply (install a compressed air dryer upstream of the control).

1-3. Excessively long runs of tubing (50 feet or greater) between the sensor and control can create backpressure resulting in an elevated "air-on" reading. One way to reduce the backpressure is to move the control closer to the sensor.

1-4. Creases on the face of the diaphragm can restrict exhaust air flow through the vent nozzle. This creates additional backpressure and may only be noticed when tank is empty.

1-5. Excessive air flow from Sensor Control (over 2 CFH) will produce visibly higher "air-on" and possibly create a pressure bias affecting the output signal at all times. Check for air flow using a rotameter connected to the "P" purge port of the control (specified nominal flow is 0.8 to 1.2 CFH). Also check that the compressed air supply pressure connected to the "CA" port does not exceed 150 PSIG. (Air Control Section of the Sensor Control may require service and replacement parts.)

1-6. D/P Sensor Controls Only - Check "zero" output of D/P transmitter portion of Sensor Control.

Note: When adjusting the zero output of the 768 D/P Sensor Control with the compressed air supply turned off, or with the tubing at the "S" port (signal input pressure) disconnected at the control unit. This is because of the initial "air on" effect from the diaphragm unit (see below) that occurs when liquid level is below the sensor. This "air on" effect will disappear once the slighted pressure is exerted against the diaphragm face of the sensor, therefore this effect should not be compensated for when adjusting the "zero" setting.

1-7. Check column type indicator by disconnecting signal line. Indicating liquid should rest at bottom mark on scale. Too much indicating liquid will result in a slightly high reading.

Digital indicator normally displays a "reserve" value (corresponding to the capacity of the tank below the sensor). Even when tank is completely empty the reserve will normally be displayed.

Typical "Air-On" Values for TeleSensor Units

The 'AIR-ON' value refers to the slight pressure output of the sensor and control even when tank is empty or level is below point where the sensor diaphragm is located.

External TeleSensor -

w/ 760-Series Sensor Control: typically 0.6" - 0.9" w.c.

w/ 860-series Sensor Control: typically 0" - 0.2" w.c.

Internal TeleSensor -

w/ 760-Series Sensor Control: typically 0.6" - 1.0" w.c.

w/ 860-series Sensor Control: typically 0" - 0.3" w.c.

Above values are in inches of water column (w.c.)

Symtom #2
Negative Reading (Tank Partially or Completely full)

This condition is defined as having a negative reading. Indicating liquid in column indicators may drop below sight in the glass tube. Digital indicators may display "E____0", or other tank reserve value even though tank is partially or completely full.

2-1. Non-Vented Tank (Differential Pressure Measurement) - Check that the high and low pressure signals are properly connected to the indicator or D/P transmitter. High pressure (signal from lower sensor) and low pressure (signal from "equalizer" or upper sensor) could be reversed causing a negative reading. Refer to the following illustrations:

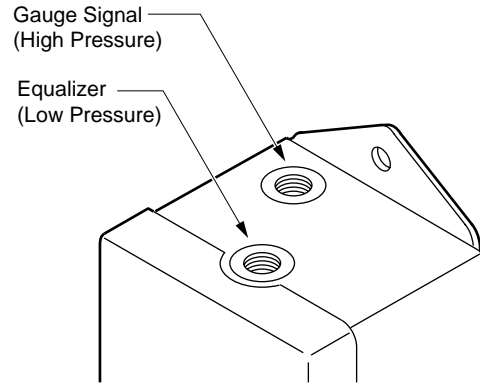

King-Gage Column Indicator

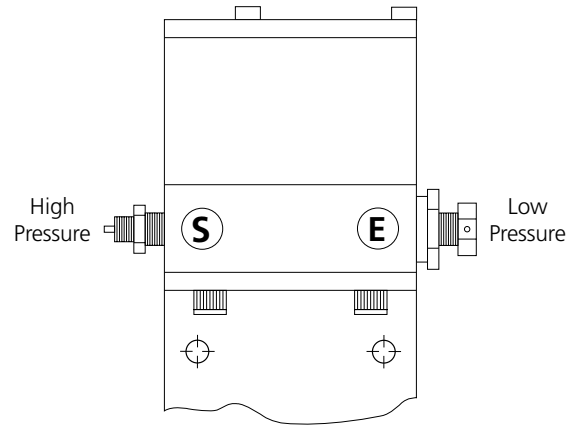
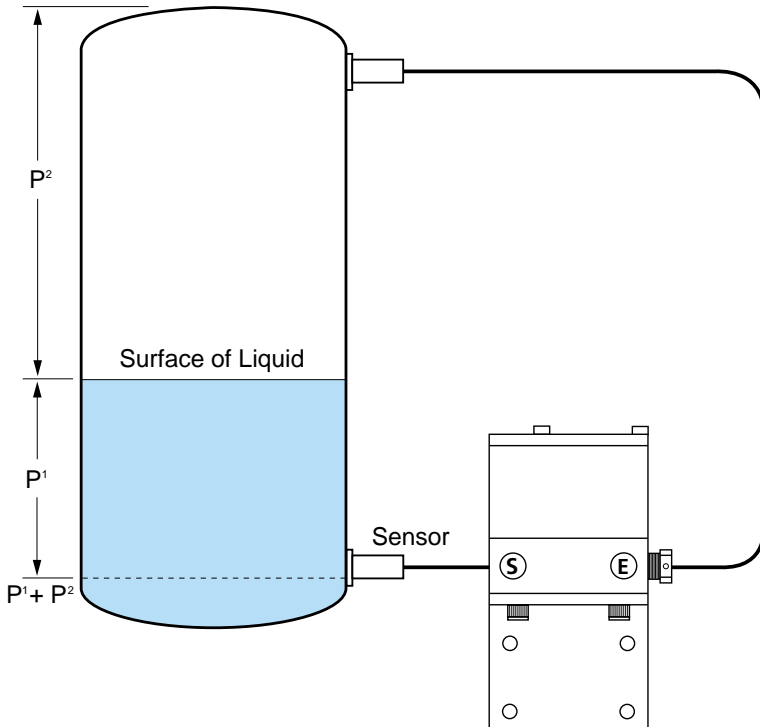

D/P Module Transmitter

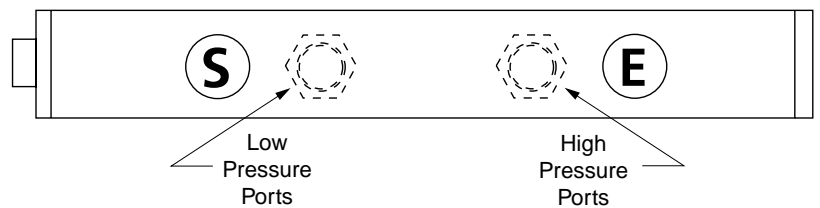

D/P Transmitter

Symptom #3**High Reading (Tank Empty or Full)**

This condition is defined as having consistently high readings, regardless of whether tank is empty, partially or completely full.

3-1. Check column type indicator by disconnecting signal line. Indicating liquid should rest at bottom mark on scale. Too much indicating liquid will result in a consistently high reading.

If equipped with Overflow Check Valve, remove and test. Shake valve . . . you should hear the float rattle. If indicating liquid drops in gauge when valve is removed, valve may be stuck shut.

Check column type indicator (if applicable) and determine whether indicating liquid is same as noted on side of scale.

3-2. Check for liquid in tubing between TeleSensor and Sensor Control.

3-3. Possible restriction in vent tube or malfunction of backpressure regulator within Sensor Control. Disconnect vent tube at "V" vent port of Sensor Control. If reading drops, restriction exists within control. If reading remains high, check for kinks in the tubing run.

3-4. Tank may not be adequately vented to atmosphere. (Tanks that are heated may create elevated internal pressure if vents are closed or restricted.) If tank is closed, pressurized or inadequately vented to atmosphere, an equalizer must be installed for measuring differential pressure.

3-5. D/P Transmitter or D/P Sensor Control - Check zero adjustment of transmitter with signal tubing disconnected from the "S" port of the control, or with compressed air supply turned off.

* Discontinued model. Use of ratio controls is not recommended due to reduced accuracy.

3-6. If the tank has an agitator, the sensor may be affected by product flow across the face of the diaphragm creating a high reading. Turn off agitator and check if reading drops.

3-7. Excess air flow from "P" purge port of Sensor Control. Use a rotameter connected to the control to measure actual flow rate. Flow above 2 CFH will cause noticeably high readings. (Specified nominal flow rate is 0.8 to 1.2 CFH)

Note: A common cause of excess flow is due to bad O-ring seal on the internal flow orifice of the Sensor Control. Another cause results from enlargement due to attempted cleaning of the orifice using a wire or pin. The diameter of the orifice is critical in producing the desired 1 CFH flow rate.

Additional Note Regarding Inaccurate Readings

King-Gage Column Type Indicators

Indicating liquid used must be the same as is noted on the indicator scale. These liquids are color-coded as to their specific gravity. Using the wrong specific gravity liquid will create inaccurate readings.

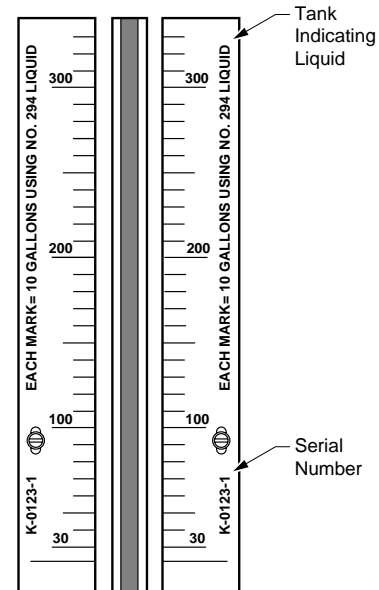

King-Gage Digital Indicators

The Personality Datapack must be installed in the digital indicator. The Datapack can be used only to gauge the specific tank for which it was programmed. Always make certain that Datapack(s) are installed in the appropriate indicator.

Any Changes?

Has the pitch of tank been changed? This can affect accuracy (since the actual capacity curve will be changed from that for which the scale/datapack was made). Another possibility is the specific gravity of tank product is heavier than value used to calculate the scale/datapack.

Symptom #4**Low or No Reading (Tank Partially or Completely Full)**

This condition is defined as having low readings, or even no reading when tank contains product. No reading, however, does assume that compressed air supply is turned on at Sensor Control.

4-1. Check that all tubing is connected at TeleSensor and Sensor Control. Also check tubing and connections for leaks. Small leaks may cause low readings only at upper levels in the tank. Generally, it is best to look for leaks when tank is completely full and system is fully pressurized.

4-2. If Sensor Control includes a SafeGard, it is possible that the pressure setting is not correctly adjusted. When no reading exists, the SafeGard may be set so low that virtually no signal pressure is going to the indicator. If readings stop suddenly, even though tank level continues to increase, the SafeGard setting is too low.

4-3. If readings are consistently low, it could be that the tank contains a lighter specific gravity product than was calculated for the indicator. If incorrect capacity data was furnished, this would result in inaccurate (low) readings.

Also note whether tank pitch has been changed as this can affect accuracy (since the actual capacity curve will be changed from that for which the scale/datapack was made).

4-4. Column type indicator (if applicable) - Determine whether indicating liquid is same as noted on side of scale.

Also check to see if vent plug is correctly installed at top of glass tube. If equipped with Overflow Check Valve, remove and observe gauge reading. If reading rises, check valve may be sealed shut. Inspect for proper operation by shaking. The internal float element should rattle audibly if operational. If no rattle is heard, check valve may need to be replaced.

Overflow Check Valve

KING-GAGE column indicators are often equipped with a float-type check valve to prevent indicating liquid from escaping out the top of the glass tube during overpressure (overrange) conditions. After an indicator has been overpressured, it is recommended that the check valve be cleaned to remove traces of indicating liquid that may foul the internal float of the check valve assembly. Soak the assembly in alcohol unless gage fill is mercury.

4-5. D/P Transmitter or D/P Sensor Control - Check zero adjustment of transmitter with signal tubing disconnected from the "S" port of the control or with compressed air supply turned off.

If there is no output from D/P transmitter, check that signal wiring has been properly connected to "+" and "-" terminals. (If reversed, no electrical current will flow through transmitter.) Also check that signal loop wiring is hooked up to source of DC electrical power.

4-6. If the tank has an agitator, the sensor may be affected by product flow across the face of the diaphragm creating a pressure drop. Turn off agitator and check if reading rises.

4-7. If low readings occur only at upper tank levels, compressed air supply pressure may be set too low. (Refer to page 9 for supply pressure requirements.)

4-8. Check diaphragm face for creases or distorted appearance which may affect function of the internal vent nozzle. If the diaphragm has been exposed to high pressure (100 PSIG or greater), it may appear to be "ballooned" outward.

4-9. It is possible that product or condensation has contaminated diaphragm capsule. Check for signs of liquid in tubing between TeleSensor and Sensor Control. Also inspect tubing run to indicator (if applicable) for kinks or liquid contamination.

4-10. Check Sensor Control air flow from "P" purge port. Normal air flow is approximately 1 CFH. Partial blockage of the internal flow orifice can reduce air flow to sensor resulting in low readings.

Symptom #5**Reading Stops Rising While Tank is Being Filled**

This condition is defined as having normal readings at lower levels in the tank. However, at some point readings stop rising even though tank level increases as filling continues.

5-1. If Sensor Control includes a SafeGard, it may be adjusted too low. This will cut-off gauge signal as the pressure increases. Check SafeGard pressure setting and adjust upward if necessary.

5-2. Check all tubing and connections for leaks. Some leaks may only occur at upper tank levels when pressure is higher. If possible, leak-check system when this condition occurs.

5-3. Compressed air supply pressure may be too low to balance liquid head. (Supply pressure should be at least 20 PSIG greater than liquid head pressure. Refer to page 9 for supply pressure requirements.)

5-4. Digital Indicators - If reading stops increasing and letter "H" appears on left side of display, top calculated value has been reached. Some older model King-Gage digital indicators will display "EEEEEO9" when the signal applied exceeds range of indicator. This may be due to fact that liquid product has heavier specific gravity than that which was used to calculate the datapack.

Always check that datapack is installed in correct digital indicator (or proper mounting socket in expansion chassis on multiple tank digital indicators).

5-5. Column Indicators - Check that vent plug is installed at top of glass tube. If equipped with Over flow Check Valve, remove and inspect for contamination or malfunction. (When shaken, the internal float should rattle audibly if functional.)

5-6. Check for the possibility that the sensor diaphragm has a small hole permitting air to leak out.

Symptom #6**Overpressure Condition (Overrange Signal)**

This condition is defined as pressure signal exceeding range of indicator (or D/P transmitter, if applicable).

6-1. Tank may be filled into riser pipe/tank vent. This may exceed range of indicator if added height of riser/vent was not used to calculate actual range required.

6-2. Tank product is of a higher specific gravity than was originally calculated. This will result in higher pressure signals which may exceed the range of the indicator.

6-3. Possible restriction or blockage of vent tube. Also, possible malfunction of backpressure regulator within Sensor Control prevents venting of exhaust air from TeleSensor. This may also be caused by a plugged vent hole on rear of Sensor Control.

6-4. Tubing is improperly connected at Sensor Control. If gauge line is mistakenly connected to "P" purge port of control, signal to gauge may go to full line pressure.

6-5. D/P Transmitter or D/P Sensor Control - If wrong range of transmitter was ordered, pressure output of TeleSensor may exceed full scale of transmitter. If transmitter output exceeds 20.00 mA, some older model King-Gage digital indicators may display "EEEEEO9" (overrange).

6-6. Closed or inadequate vent on tank may create internal pressure above liquid product when tank is being rapidly filled. Check that tank vent is clear and unobstructed.

6-7. Non-Vented (Differential Pressure) Application - If upper sensor is disconnected or low pressure input at indicator is disconnected, unequalized high pressure signal may exceed range of indicator.

If low pressure input ("E") at D/P Transmitter or D/P Sensor Control is disconnected, unequalized high pressure signal may exceed range of transmitter.

Symptom #7 Fluctuating or Bouncing Readings

This condition is defined as having severely unstable readings. It may also be manifested by "bouncing" (e.g. rapid variations between high and low readings).

7-1. Sensor may be affected by tank agitator (if applicable). Turn off agitator and observe if reading stabilizes.

7-2. Possible liquid or product in tubing between TeleSensor and Sensor Control. If a small amount of liquid collects at a bend in the tubing, it may create pressure fluctuations. (Inspect vent tube and signal tubing for possible liquid accumulation.)

Recurring evidence of moisture (not tank product) is generally condensation resulting from an inadequately dry compressed air supply. A coalescing filter and compressed air dryer may be required for installation in the main supply line.

7-3. Column type indicator - Check indicator to determine that indicating liquid is same type as noted on side of scale.

If small bubbles are occasionally seen within the glass tube of the indicator, there may be insufficient indicating liquid. Remove signal line from gauge and check that indicating liquid rests at lowest mark on indicator scale.

Addendum

Older-Style TeleSensor Diaphragm Units

2-Line System with Air Control

Note - older versions of TeleSensor units cannot be used with 760-series Sensor Controls.

These versions of the TeleSensor diaphragm unit are now obsolete. Used in conjunction with an old-style air control package, this 2-line sensor does not incorporate a backpressure regulator. Due to this fact, the sensor does not provide a true 1:1 pneumatic output signal. If this type of TeleSensor is used with a King-Gage Digital Indicator, the datapack must be made using a special factor to compensate for the non-standard output. Otherwise, the indicator will be inaccurate and provide slightly high readings.

The Air Control package has an air flow orifice installed at the connector block. This type of flow orifice must be carefully sized based on the regulated compressed air supply - see callouts below. If desired, the existing air control package (now obsolete), can be replaced with a standard 780-series Purge Control for this type of older 2-line TeleSensor unit.

Addendum

Older-Style TeleSensor Diaphragm Units with Air Flow Snubber Screw

These older versions of the TeleSensor incorporate a snubber screw (see illustration) to regulate air flow to the diaphragm unit. Now obsolete, these units were originally supplied with compressed air directly from a pressure regulator. These units generally have a 1:1.006 ratio of applied liquid head to output pressure. Any adjustment to the snubber screw that changes the actual internal flow may affect the accuracy of the pressure signal transmitted to the King-Gage Indicator.

Retrofit - This unit can be used with a 780-series Purge Control only if the snubber screw assembly is removed. The threaded port must then be sealed with a short plug (1/4" length or less).

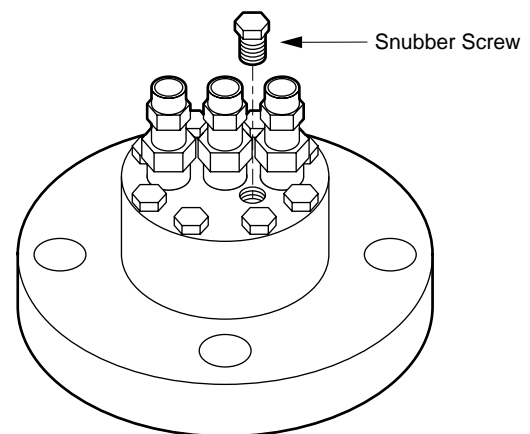



Box 1228, Ann Arbor, Michigan 48106-1228 U.S.A.
Phone: (734) 662-5691 ▪ FAX: (734) 662-6652